

AUTOMATIC PANEL MOUNT UNITS

OVERVIEW

Automatic Panel Mount Unit is used to control air / water flow of syringe and handpieces. The dental delivery system contains panel mount control, foot control, the instrument holder bar (with syringe and handpieces), and the utilities.

Panel Mount Control

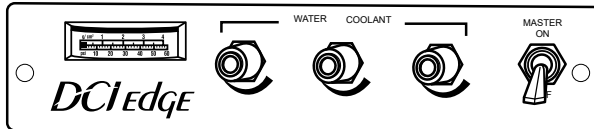

Foot Control

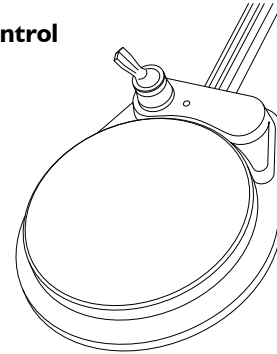

The Automatic Panel Mount Unit is applicable to the dental delivery systems 4415, 4460, 4404L, and 4404R. Instruments holder configuration for each PN is shown below.

4415

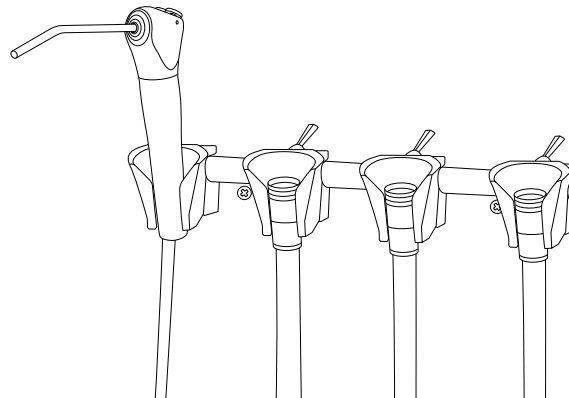

4460

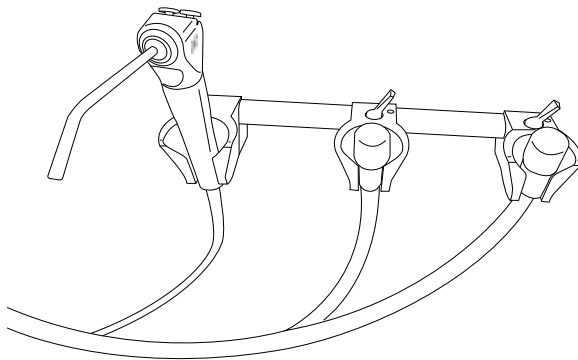

4404L, 4404R

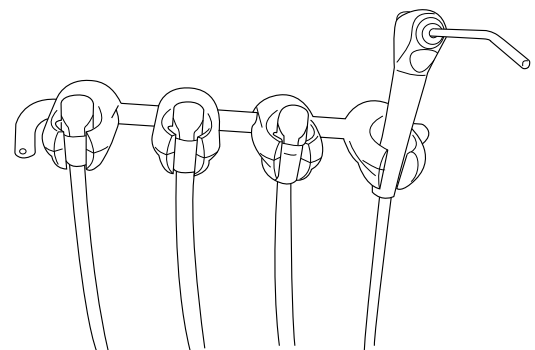

INTRODUCTION

SYMBOLS

The following symbols may be used throughout this product manual:



WARNING: Failure to carefully follow the described procedure may result in damage to the equipment or the operator.



CAUTION: Failure to carefully follow the described procedure may result in damage to the equipment.



NOTE: Take note of additional important information. Not a warning or caution.



ELECTRICAL HAZARD: Risk of electrical shock present. Ensure that power is disconnected before attempting procedure.



Manufacturer



Manufacturing date



Electrical Testing Lab



Waste Electrical and Electronic Equipment



Conforms to applicable European Directives (Essential Requirements)



Advisable to consult accompanying documents

TABLE OF CONTENTS

Overview	2
Introduction	3
General Information	4
General Safety	6
Operations	7
Adjustments	8
Maintenance	9

GENERAL INFORMATION

INTENDED APPLICATION AND USE

The dental delivery system is a device intended to support the instruments used by the dental practitioner, delivering those instruments to an accessible position during a dental procedure. This device may control and be the means of delivering compressed air, water, vacuum and low voltage electricity to a variety of instruments commonly used in dental practice.

PRODUCT IDENTIFICATION

This device can be identified by the label on the underside of the dental delivery system head. This label states the model number, serial number, electrical specifications, manufacturing date, software version, and safety classifications. Note the **sample** label at right.

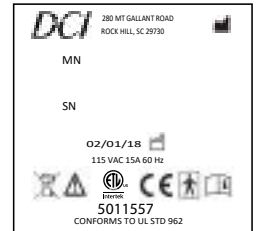

APPLICABLE MODEL

ACU

AIR AND WATER SUPPLY

AIR
Air Quality: Dry and clean
Pressure: 80-105 psi

WATER
Water Quality: Potable
Hardness: 7.2 - 7.8 pH
Pressure: 40-80 psi

ELECTRICAL SPECIFICATIONS

100-240VAC | IEC Medical Classification: 2A
.6 Amps | TYPE: BF Power optics
50-60Hz | Splash Protection: IPX0

ACCESSORY DEVICES:

Power Optics:

Operation: Intermittent
Duty cycle: 20 sec ON, 10 sec OFF, 10X/hr

ENVIRONMENTAL CONDITIONS

Operating Conditions:
Temperature: 67-76° F
Humidity: 20-60%

Shipping conditions:
Temperature: -68 - 122° F
Humidity: 10-90%

TECHNICAL DOCUMENTATION

The manufacturer will make available upon request circuit diagrams, component part lists, descriptions, and calibration instructions to technical personnel responsible for the installation and service of this equipment.

PRODUCT DISPOSAL

Contact your local, authorized dealer for disposal of this device to ensure compliance with your local environmental regulations.

GENERAL INFORMATION

PREVENTATIVE INSPECTION

The performance of the equipment can be affected by use over time. Periodically inspect the water and air lines for visible cracks or cuts and inspect for loose fittings and fasteners which could lead to leaks or other poor performance characteristics. Inspect joints and tensioning screws as a regular maintenance item to ensure proper positioning of the device. See **“Adjustments”** and **“Maintenance”** sections of this manual for detailed instructions.

PRE-USE REQUIREMENTS

All operators of this device must read this document in its entirety before use.

Ensure that all installation steps are completed by a trained technician as described in the Installation Instructions for this device.

Ensure all functions and features as defined in the **“Operations”** section of this manual are operating properly.

Ensure all ancillary devices are connected and functioning properly.

Follow the instructions on dental waterline treatment in the **“Maintenance”** section of this manual before first time use of this device.

Follow the instructions on cleaning, disinfecting, and sterilization in the **“Maintenance”** section of this manual before first time use of this device.

Ensure that all staff responsible for the maintenance, disinfection, and cleaning of this device are fully trained on the information provided in the **“Maintenance”** section of this manual.

GENERAL SAFETY

WARNINGS & CAUTIONS



WARNING: This product must be disinfected before use.



CAUTION: Only authorized service technicians should attempt to service this equipment. Use of other than authorized technicians will void the warranty.



WARNING: Modification of this equipment is not allowed.



WARNING: Failure to disinfect this device between patients could expose the user and patient to cross contamination and bio-burden/biocontamination.



WARNING: Failure to return handpieces to their proper locations could result in alternate or additional handpieces operating without notice.



WARNING: Proper personal protective equipment (PPE) including but not limited to gloves and eye protection must be used when cleaning debris trap.



WARNING: Do not allow children unsupervised access to the dental delivery system and auxiliary equipment.



NOTE: This product is intended for use by trained dental/medical professionals only.

OPERATIONS

CONTROLS

The *master on/off toggle* controls air to the entire control system. It is located on the right front of the panel mount control.

The *drive air pressure gauge* indicates the operating pressure of the selected handpiece. It is located on the left front of the panel mount control.

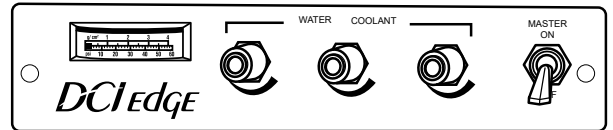

The *water coolant flow control knob*, one for each handpiece, controls water to the active handpiece. They are located on the front of the panel mount control, to the right of the drive air pressure gauge.

The *water coolant on/off toggle* controls the air signal to the water coolant relay. It is located on the standard foot control; the On position is with the toggle toward the blue dot.

The *drive air adjustment screws* are located on the Tri-block inside the panel mount control. Handpiece drive air pressures should be adjusted to the handpiece manufacturer's recommendation. See the section **“Handpiece Drive Air Operating Pressure”** on page 8.

FOOT CONTROL

The foot control is a standard disc style with wet/dry toggle. Handpiece speed is controlled with the foot control disc. Varying pressure on the foot control disc controls speed. Air coolant is also provided when you step on the foot control disc.

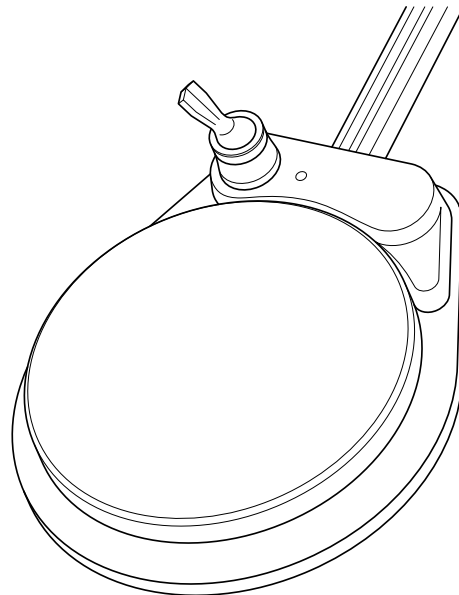

ADJUSTMENTS

SYRINGE BLOCK

Syringe adjustment screws are located in the back left corner on the bottom of the panel mount control.

Use the 3/32" hex key provided with the control to make the adjustments. Turn the screws clockwise for less flow, and counterclockwise for more flow. As you face the control dental delivery system, the adjusting screw for air is on the right, and the adjusting screw for water is on the left.

HANDPIECE DRIVE AIR OPERATING PRESSURE



NOTE: All of the following adjustments should be made with a bur in the handpiece. Running a handpiece without a bur can damage the handpiece.

Refer to the manufacturer's literature to determine the recommended drive air operating pressure for your handpieces.

You will need a small blade screwdriver to make these adjustments. Install a bur in the handpiece to be tested.

The master on/off toggle must be in the On position. Place the water coolant on/off toggle on the foot control in the Off position (away from the blue dot). The handpiece will operate automatically when removed from the automatic handpiece holder. Step on the foot control disc until the handpiece is running at maximum speed. Drive air pressure adjustment screws are located on the top of Tri-block, and order is facing front of panel, left to right, with #1 being on the left, #2 in the middle and #3 on the right. The handpiece holders are mounted on the holder bar in the same order, with #1 being to the right of the syringe holder. Turn the drive air adjustment screw counterclockwise until the drive air pressure gauge reads a little more than the recommended operating pressure. Then turn the screw until the pressure gauge indicates the recommended operating pressure. The handpiece drive air operating pressures should be adjusted in accordance with the manufacturer's recommendation. Repeat this step for the remaining handpieces.

HANDPIECE WATER COOLANT ADJUSTMENT

Place the water coolant on/off toggle on the foot control in the On position (towards the blue dot). Install a bur in handpiece being adjusted. Press on the foot control disc until the handpiece is running at half operating speed. Adjust the water coolant flow control knob (same order left to right as handpiece positions on mounting bar) until a fine spray is present around the bur. Very little water coolant is required to attain the appropriate spray pattern.

MAINTENANCE

BARRIER TECHNIQUE

Wherever possible, use disposable barriers and change them between patients. The barrier technique will ensure maximum long term durability of the surfaces and finishes of the equipment.

CLEANING

Dental equipment, categorized as noncritical devices with low risk of infection transmission, come into contact only with intact skin. Before applying disinfectant, clean the surfaces with a mild detergent and a clean cloth to remove unwanted dirt and debris.



CAUTION: Do not use powdered cleansers, scouring pads or abrasive scrubbers on any of the painted, plastic or metal surfaces of this dental delivery system. To remove dried-on material, use a soft bristled brush and a solution of mild detergent.

CHEMICAL DISINFECTION

Follow the instructions below carefully to ensure the longest life for your equipment:

1. Only use the acceptable disinfectants listed. Use of unacceptable products may void your warranty.
2. When applying chemicals with a spray bottle, **do not spray surfaces directly**. Instead, spray a cloth and then wipe the surfaces with the wet cloth.
3. When using chemical disinfectants, always pay strict attention to the manufacturer's disinfectant directions.
4. When using concentrated disinfectants, measure the concentrate carefully and mix according to package directions. **Disinfectant solutions at higher than recommended dilution ratios are extremely corrosive.**
5. Thoroughly wash all areas that have been exposed to disinfectant cleaners with mild soap and warm water at least once per day. This wash down will minimize the harmful effects of chemical disinfectant residues being allowed to accumulate on the equipment.

Conditionally Acceptable Disinfectants

- Phthalaldehyde
- Quarternary Ammonium
- Glutaraldehyde



CAUTION: These disinfectants will harm the surface finish of dental equipment and are not recommended.

Unacceptable:

- Strong Phenols/Phenol Alcohol combinations
- Sodium Hypochlorite/Household Bleach
- Sodium Bromide
- Strong Alcohol
- Household Cleaners (Dental Equipment Only)
- Citric Acids
- Iodophors
- Ammonium Chloride
- Accelerated Hydrogen (0.5%)

STERILIZATION

Among the various sterilization methods available, it is vital to remember that temperatures must not surpass 275°F (135°C) regardless of your chosen approach.

The recommended sterilization method is Steam Autoclave.

1. To prepare the instruments, begin by cleaning them under running water for 30 seconds using a soft brush.
2. Subsequently, place the instruments in an ultrasonic bath with an enzymatic cleaner to thoroughly remove superficial debris.
3. This step is crucial to enhance the overall effectiveness of the sterilization process.
4. For wrapped instruments, ensure that the parameters are set at 132°C (270°F) for 15 minutes, with an additional 30-minute drying time, especially when utilizing a gravity displacement autoclave.
5. For unwrapped instruments, the recommended parameters are 132°C (270°F) for 3 minutes, maintaining a temperature-controlled environment within a gravity displacement autoclave.

MAINTENANCE

DENTAL DELIVERY SYSTEM WATERLINES

Dental delivery system waterlines are susceptible to contamination by various microorganisms, including slime-producing bacteria, fungi, and protozoans. These contaminants colonize the inner surfaces of waterline tubing, giving rise to biofilms – complex microbial accumulations.

Biofilms: Biofilms are prevalent in natural environments, thriving wherever there is moisture and a suitable surface for attachment.

Source of Contamination: Water entering dental facilities from city supplies or wells carries non-sterile waterborne bacteria and trace nutrients. This creates an environment conducive to bacterial attachment and biofilm development within waterlines.

Amplification and Reservoir: Biofilms serve as a reservoir, substantially increasing the concentration of microorganisms in the water exiting the dental delivery system waterlines. The amplified microbial load includes clinically significant pathogens

such as *Pseudomonas*, *Legionella*, and non-tuberculosis *Mycobacterium* species.

Water Quality Standards: Water used for dental procedures should meet nationally recognized microbial standards. The maximum permissible limit for heterotrophic, mesophilic water bacteria is set at 500 CFU/mL, consistent with drinking water standards.

Caution with Water Heating: While heating water has been practiced for patient comfort, it's important to note that warming water can inadvertently promote biofilm formation and the growth of organisms adapted to human hosts. Caution should be exercised when considering water heating practices.

Waterlines Maintenance Schedule: Recent advancements in infection prevention for dental delivery system waterlines have

highlighted the significance of a well-structured waterline maintenance protocol. The following three fundamental steps are integral to an effective waterline maintenance approach:

Monitoring Water Quality: To ensure the maintenance of water quality, regular monitoring should be conducted using appropriate monitoring kits. Follow the instructions provided by the manufacturer for accurate usage of the monitoring kits. Regular monitoring will enable timely identification of any deviations from the desired water quality standards, allowing for prompt corrective measures to be taken.

Shocking Treatment: Should the results indicate elevated levels of microbial contamination or other deviations from desired standards, use a shock treatment to bring your water back into compliance. This procedure involves the application of a potent disinfectant, to thoroughly eliminate contaminants. This treatment eradicates major buildup, ensuring a fresh start for the waterlines. Shocking is a pivotal step in preparing your new dental equipment waterlines for first time use.

Routine Treatment: Following the initial shocking process, sustained cleanliness is maintained through the use of treatment products. These products effectively reduce and hinder the re-growth of bacteria, sustaining the sanitized conditions achieved through shocking.

Disinfectants for the Dental delivery system Waterlines: For effective disinfection of dental delivery system waterlines, the use of disinfectants containing, chlorhexidine or iodophor has shown the best results. These disinfectants have demonstrated high efficacy in eliminating microbial contamination and maintaining waterline cleanliness.

The following commercially available products are suggested for waterline treatment:

- **DentaPure™** — Microbiological Dental delivery system Water Purification System – Iodine-based cartridge system by Crosstex
- **Liquid Ultra™** — A hydrogen peroxide based, two part liquid solution by Crosstex

It is important to follow the instructions provided by the manufacturers for proper usage of these products to ensure optimal results in maintaining waterline cleanliness.

MAINTENANCE



WARNING: During the product evaluation carried out by the American Dental Association (ADA), Chlorox™ Regular Bleach, sodium hypochlorite, showed favorable results. However, it is important to note that scientific literature has indicated the potential toxicity of this substance to individuals.



WARNING: Due to its corrosive nature, sodium hypochlorite can pose a risk to users' skin and mucous membranes upon contact. Therefore, careful consideration is advised when contemplating the utilization of this product for dental delivery system waterline treatment. Furthermore, it should be noted that apart from its potential toxicity to patients, sodium hypochlorite can also cause damage to internal components of the dental delivery system. Consequently, the use of bleach solutions should be avoided.

DENTAL DELIVERY SYSTEM WATERLINE DISINFECTION PROCESS

To ensure effective disinfection of dental delivery system waterlines, the process should involve the use of a combination of distilled water and a suitable disinfectant. Be sure to follow the manufacturers instructions.

1. Start by filling the water reservoir of the dental delivery system.
2. Add the recommended amount of the chosen disinfectant to the water in the reservoir. Follow the manufacturer's instructions for the correct dosage to achieve the desired disinfection efficacy.
3. Remove all handpieces (including slow speed handpieces) and any accessories connected to handpiece tubings.
4. Activate the water system and allow the mixture of water and disinfectant to flow through the waterlines for the recommended duration specified by the disinfectant manufacturer. Ensure that the water flows through all water-bearing lines, including quick-disconnect lines and other relevant components. This ensures that the disinfectant reaches all parts of the waterlines, effectively eliminating microbial contamination.
5. After the recommended contact time, thoroughly flush the waterlines with clean distilled water to remove any residual disinfectant solution.

DAILY PURGING OF WATER-BEARING LINES

To ensure a clean and uncontaminated water supply, it is crucial to perform daily purging of all water-bearing lines at the beginning of each workday. This process involves thorough flushing of the waterlines for a minimum duration of two (2) minutes. The purging should encompass all relevant lines, including handpiece and syringe lines, quick-disconnect lines, and any other applicable lines.

Follow these steps for effective daily purging:

1. Activate the water system and open all handpiece and syringe flow valves to allow water flow through the lines.
2. Flush the waterlines with water for a minimum duration of two (2) minutes. Ensure that the water flows through all water-bearing lines, including quick-disconnect lines and other relevant components.
3. Pay careful attention to each line to ensure thorough flushing and removal of any stagnant water or debris.
4. After purging, remove the bottle and set upside down on a counter.

MAINTENANCE

PURGING AIR AND WATERLINES AFTER EACH PATIENT

To maintain cleanliness and prevent cross-contamination, it is essential to perform purging of air and waterlines after every patient. This protocol ensures the removal of any residual fluids or contaminants from the lines. The purging process should include both air and waterlines and should be carried out for a minimum duration of 20 seconds.

Follow these steps for proper purging after each patient:

1. After completing the dental procedure, ensure that all handpieces and other devices connected to the air and waterlines are turned off.
2. Leave all handpieces and devices that had been used during last procedure in place.
3. Activate the air and water systems to allow the flow of air and water through the lines.
4. Purge the air and waterlines for a minimum duration of 20 seconds. This helps flush out any remaining fluids, debris, or potential contaminants from the lines.
5. Monitor the purging process to ensure adequate flow and complete removal of any residual substances.
6. After purging remove all used handpieces and accessories for cleaning and sterilization.



WARNING: In order to mitigate the risk of cross-contamination between patients, disinfection and sterilization of handpieces must occur after each dental procedure. Refer to the handpiece manufacturer's instructions and recommendations for sterilization or disinfection procedure.

SELF-CONTAINED WATER SYSTEM

The self-contained water system is designed to optimize the quality of water being delivered to the handpieces and syringes. The self-contained water system has three functions:

- The system may be filled with filtered or sterile water for patient use.
- The system may be filled with disinfectant for flushing the syringe and handpiece tubing.
- The dental delivery system can be purged with air to inhibit the growth of biofilm.

In order to maintain a truly aseptic water system, daily and weekly cleaning procedures must be performed in a consistent, regular manner. Failure to do so could result in contaminated water lines and a lower water quality than what is acceptable for patient use. Follow a daily and weekly maintenance routine for proper cleaning of the tubing with the clean water system.

DISINFECTING THE BOTTLE



CAUTION: Disinfect new water bottle prior to first use.

Fill bottle with the 100 ml disinfectant solution, shake vigorously and let it settle for 10 minutes. Shake again, and then rinse twice with water.

It is recommended that 100 ml of disinfectant solution is mixed for each weekly bottle disinfecting procedure. Always use a fresh mixture every week.

The Disinfectant Solution:

- 9 parts (90 ml) Tap water
- 1 part (10 ml) 5.25% Sodium hypochlorite (household bleach)

MAINTENANCE

REPLACEMENT COMPONENTS

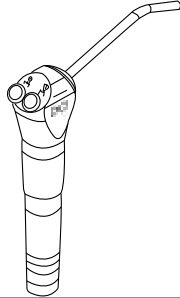
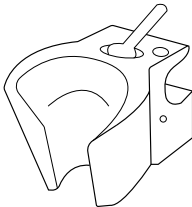
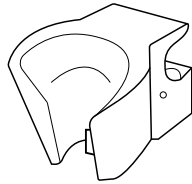
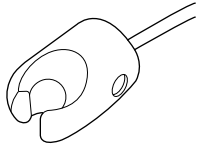
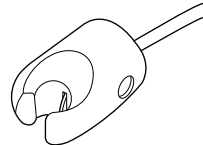
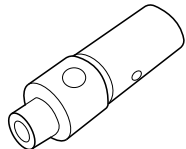
PN	Description	Illustration
3600	Sringe, Precision Comfort, Less Tubing & Kit	
5960	Holder, Auto HP, w/Lockout Toggle	
4592	Holder, Auto HP, w/o Lockout Toggle	
4568	Holder, Standard, Molded Gray	
4559	Holder Auto HP	
7068	Water Relay, Non-Retracting	



PN 91681, Rev. K, 2024-04-29

www.dcionline.com
800-624-2793



DCI International, LLC
705 S. Springbrook Road Bldg C
Newberg, OR 97132, USA