

AUTOCLAVABLE VALVE CORE SYRINGE

**3368, 3369, 3370, 3374, 3375, 3376,
3377, 3378, 3379, 3398, 3399, 3404**

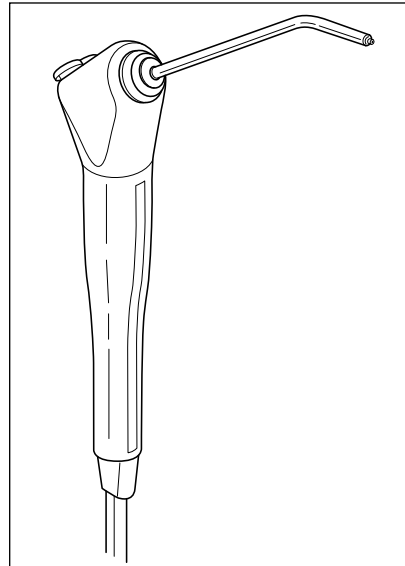

**Figure 1: The DCI
Autoclavable Valve Core Syringe**

Your new autoclavable syringe from DCI represents the highest level of engineering achievement in the dental equipment industry today.

This 3-way syringe gives precise finger-tip control of water, mist or dry air for rinsing, cooling or drying the preparation area.

Your syringe is totally autoclavable, up to 135° C, and features DCI's patented Quick-Change tip system for maximum patient safety.

By following these use and maintenance instructions, this syringe will provide a lifetime of dependable service.

USE AND CARE

SYSTEM PRESSURES

This syringe is engineered to operate with air pressure of 60-80 psi and water pressure of 30-40 psi. These are the pressures at which most dental units operate. Excessive pressure may cause erratic performance or leakage, so you should check system pressures and make adjustments as necessary.

SYMBOLS

The syringe head is imprinted with symbols indicating the button functions. The button on the left is water, and one on the right is air. Press both buttons simultaneously for steady uniform mist.

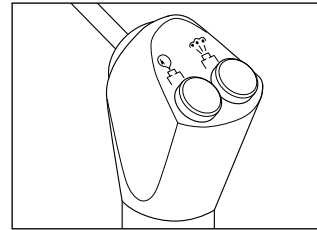

**Figure 2: The Water
and Air Symbols**

CHANGING THE TIP

A sterile syringe tip should be installed for each patient. To prevent contamination, sterile tips should be handled with a sterile gauze pad.

To remove the syringe tip, press down on the large collar. When you feel a soft "click", the tip may be pulled straight out. Hold the collar down and insert the new tip. Be sure to press it all the way in, and then release the collar.

Test the installation by giving a firm pull on the tip to assure that it is inserted all the way, and that the locking mechanism is fully engaged.

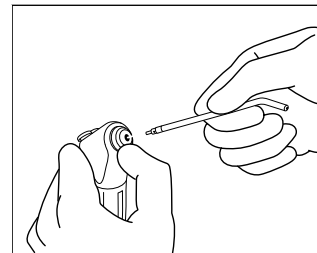

Figure 3: Changing the Tip

SYRINGE REMOVAL AND REPLACEMENT

The syringe is engineered for quick, easy removal for cleaning and sterilization. The quick disconnect feature incorporates an internal shut-off valve that prevents leakage when the syringe is removed, even if the dental unit remains turned on.

To remove the syringe, grip the gray sleeve at the base of the handle, and turn it counterclockwise a quarter turn until it stops. Pull the syringe away from the Quick-Disconnect (Q.D.) cartridge.

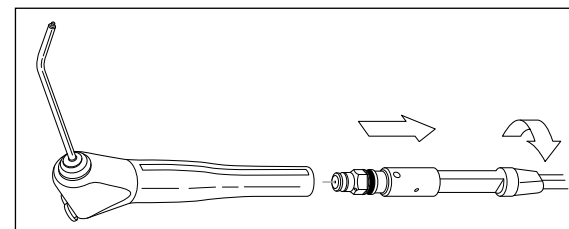

Figure 4: Syringe Removal

IMPORTANT

Note the white sleeve around the syringe tubing. This is furnished to protect the Q.D. cartridge while the syringe is away for sterilization. After removing the syringe, slide the sleeve up the tubing until the Q.D. rests in it, and then place it in the syringe holder. This minimizes risk of damage to the Q.D. cartridge or of inadvertently opening the air and water shut-off valve in the Q.D.

To install the syringe, slip the Q.D. cartridge all the way into the syringe handle, and then turn it clockwise a quarter turn until it stops. This will turn the air and water on, making the syringe operational.

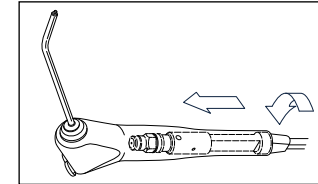
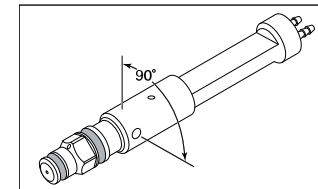

Figure 5: Syringe Insertion

If the Q.D. cartridge does not slip easily into the syringe handle, hanging up on the locking balls, it means that the shut-off valve has been rotated. Do not try to force the cartridge in. Remove the Q.D. cartridge and turn the hex-shaped portion counterclockwise as far as it goes (a quarter turn) to close the valve and allow installation of the syringe.



**Figure 6: The Q.D. Cartridge
(shut-off valve detail)**

**CLEANING, DISINFECTING AND
STERILIZATION**

CLEANING

Clean the external surfaces of the syringe using a solution of mild detergent and warm water. A soft-bristled brush may be used to clean around the buttons and tip collar.

Thoroughly rinse the syringe with clear water, then dry with a clean, soft, lint-free cloth.

IMPORTANT

Never use powdered cleansers, scouring pads or abrasive scrubbers, any of which can damage the surface finishes of the syringe. Stubborn debris can usually be removed easily after soaking in warm water.

DISINFECTING

The use of chemical disinfecting agents is not necessary if the syringe is going to be sterilized. While their use may be easy and quick, it is important to know the effectiveness of any chemical disinfectant against the various agents of infection that may be encountered.

Your dental supply dealer will have current information from all the disinfectant manufacturer's regarding their product's effectiveness. Always follow the product manufacturer's recommendations for use.

The following table lists the disinfectants commonly available through dental supply sources.

TABLE I: CHEMICAL DISINFECTANTS

Disinfectant	Brand Name	Manufacturer
Phenol/Water	BIREX se	Biotrol, Int.
Sprays	Sporicidin	Ash Div Dentsply Int'l
Glutaraldehyde	Coldspor	Matrex Research
Phenol Sprays	Procide Spray	Cottrell LTD
	Sterall Spray	Colgate Hoyt
Iodophors	Asepti-IDC	Huntington Labs
	Biocide	Biotrol, Int.
	Promedyn	Cottrell, Ltd.
	Iodo-Five	Amsco Medical Prod.
	Wescodyne	
Synergized	Cavicide	E & D
Chemicals		
Iodophor	Promedyn	Cottrell, Ltd.
Neutralizers		

NOTE

While none of the products listed in Table I will adversely affect the performance of your syringe, most chemical disinfectants can be expected to cause some degree of discoloration. This can be minimized by frequent cleaning with soap and water, and in the case of Iodophors, regular use of Iodophor Neutralizers.

STERILIZATION

Your Autoclavable syringe is specifically designed to be removed from the supply tubing for sterilization. In any situation involving high-risk patients, it is recommended that the syringe be removed for sterilization along with the other instruments used.

The Quick-Change syringe tips should always be replaced with sterile ones before each patient.

Procedures given here apply equally to the tips and the whole syringe. There are several methods of sterilization that may be used. It is important to remember, however, that regardless of the method you choose, temperatures should never exceed 280° F (138° C).

Because there are many types of autoclaves in use around the world, it is difficult to provide guidance on specific instructions of operating each. Follow the manufacturer's instructions whenever possible.

Be sure to thoroughly rinse and clean tips prior to sterilization; any debris may reduce the effectiveness of sterilization. Recommended sterilization process is steam autoclave. Recommended parameters are 125°C (257°F) for 20 minutes at temperature when using a gravity displacement autoclave.

Pressure requirements vary depending on geographic location of autoclave user.

TABLE 2: TROUBLESHOOTING GUIDE

The DCI Autoclavable Syringe is engineered for dependability. The troubleshooting guide gives the corrective action to be taken for the problems you may encounter.

Problem	Solution
Leakage around button	Replace button assembly or button O-Ring.
Leakage from Syringe tip	Replace valve core.
Momentary spray of water when air button is pressed	(A) Damaged syringe tip end: replace tip. (B) Replace the small O-Ring located behind the Quick-Change adapter.
Leakage from the syringe handle	Replace the O-Rings on the Q.D. cartridge tip. If leakage persists, replace Q.D. cartridge internal O-Rings.
Constant mist when the water button is pressed	Replace the small O-Ring on the Q.D. cartridge tip.

REPAIR

Most service that will ever be needed can be easily done using the tools and parts in the Autoclavable Syringe Repair Kit (DCI part No. 3072).

LUBRICANT

All of the internal O-Rings and valve seals will perform better if lightly coated with All Purpose Lube (DCI Part No. 8032). Anytime you replace O-Rings, they should be lubricated before installation.

BUTTON AND VALVE

Before removing the syringe button, disconnect the syringe from the Q.D. cartridge. Use a non-metallic device such as a tongue depressor or Popsicle stick to gently pry the button valve out of the syringe body. Be careful not to lose the small coil spring that is located beneath the button.

Use the valve core tool (Part No. 3096) to unscrew the valve core from the syringe body. When installing the new valve core, do not over-tighten it. Excessive tightening may impair valve operation.

Do not reinstall a used valve core because it will be difficult to get it to seal properly.

To replace the O-Ring on the syringe button, remove the old O-Ring carefully, so as to avoid damaging the button itself. Push the replacement O-Ring into its groove on the stem of the button.

Drop the coil spring into syringe body, and then carefully push the button into place.

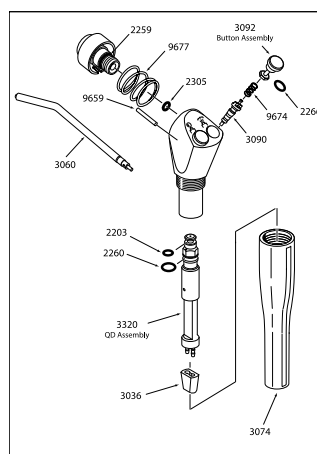

Figure 7: Illustrated Parts Breakdown

TIP ADAPTER & COLLAR

Remove the syringe tip, and then use the hex key furnished with Autoclavable Syringe Repair Kit to unscrew the tip adapter. Remove the adapter, collar and spring from the syringe body.

Use a dental pick or a bent paper clip to remove the tiny O-Ring from the bottom of the bore in the syringe body. Be especially careful not to nick or scratch the sealing surfaces. The easiest way to install the replacement is to slip it onto the end of a syringe tip, lubricate the O-Ring, and then insert it into the bore. The O-Ring around the outside of the adapter is thin and fragile, so the new one has to be installed with care.

Before reinstalling the adapter and collar assembly, look down into the bore in the syringe body and assure that the alignment pin is in place. With the spring in place in the collar, align the slot in the collar with the pin, and then push the collar into the syringe body.

Use the hex key to carefully screw in the adapter. Tighten the adapter firmly (35 in-lbs torque). If you don't have a torque measuring device, hold the hex key by the short end and tighten the adapter as tight as you can. This method installs the adapter to approximately 35 in-lbs torque.

IMPORTANT

Before performing any service on the Q.D. cartridge, it is necessary to turn off the air and water, and bleed pressure from the system by running a handpiece.

Q.D. CARTRIDGE O-RINGS

Removing the syringe from the Q.D. cartridge gives you access to the two O-Rings on the end of the adapter. A bent clip or a dental pick can be used to remove the O-Rings.

IDENTIFY THE AIR TUBE

Before undertaking further disassembly of the Q.D. Cartridge, it is necessary to identify and mark the air supply tube going to the syringe. Turn the hex shaped nut at the end of the cartridge clockwise as far as it turns (a quarter turn).

Look for the air outlet just above the hex-shaped part of the tip. The air supply tube is the one aligned directly below the outlet. Use a pen to mark the air tube for reference.

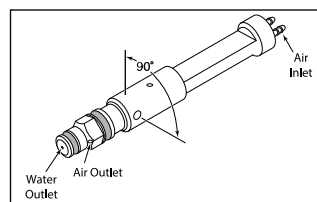

Figure 8: Q.D. Cartridge

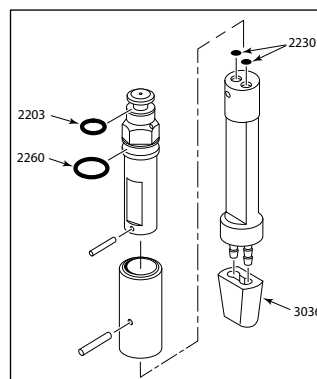

Figure 9: Cartridge Disassembly

DISASSEMBLING THE Q.D. CARTRIDGE

This service may be performed in your office, although you may prefer to leave it to your dealer service department.

Use a map pin or paper clip to push the retainer pin out of the cartridge body. Pull the two parts of the cartridge body apart. You now have access to the two tiny O-Rings on the lower part of the cartridge body.

IMPORTANT

Further disassembly of the Q.D. cartridge is needed only if there is reason to believe that foreign material has accumulated inside the upper cartridge body. There are no serviceable parts inside.

To remove the tip from the upper portion of the cartridge body, telescope the two parts, and rotate them until the retainer pin is visible in the hole from which the first retainer pin was removed. Push the pin out, and the tip can then be removed.

To reassemble the Q.D. cartridge, slip the tip inside the locking ball sleeve and align the holes. Insert the small retainer pin.

Next, hold the upper half with the air outlet facing upward. Extend the assembly to its full length and turn the sleeve clockwise. In this configuration, you can align the marked air supply tube with the air outlet in the tip.

Slip the lower part of the cartridge body into the sleeve of the upper assembly. Align the air supply tube with the air outlet, and insert the retainer pin.

Twist the tip counterclockwise to close the shut-off valve. You may now reinstall the syringe on the Q.D. cartridge.

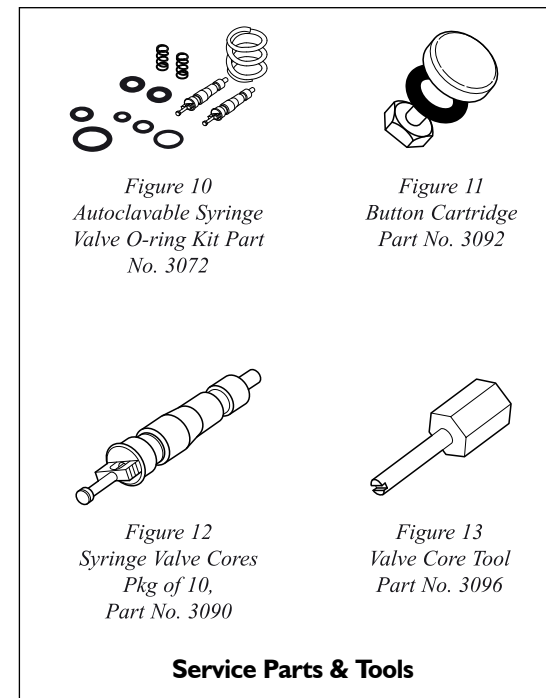

Service Parts & Tools

ONE YEAR GUARANTEE

DCI has put a lot of time and effort into designing, manufacturing or selecting all the fine products we sell. Therefore we are able to fully guarantee all our products to be free of manufacturing defects for one year from time of purchase (except the fiber optic tubings which are guaranteed for six months). Should any product fail for whatever reason due to manufacturing defect, DCI will repair or replace that product at no charge to the customer. Beyond the one-year period, we still back everything we sell with service at little or no cost to you.

You are responsible for proper care and maintenance of products purchased from DCI, and our guarantee does not cover damage resulting from improper maintenance or installation, accident or misuse. The guarantee does not cover damage resulting from use of surface disinfectants not approved by DCI.

No other warranties as to merchantability or otherwise are made.

DCI Autoclavable Syringe

US Patent No. 5,125,835, 5,199,871 & 5,234,338