

FOOT CONTROL REPAIR KIT, PN 6162

INSTALLATION INSTRUCTIONS

7. Press the two small O-Rings (PN 2205) into the bore, along with the spools, in the order shown in Figure 4.
8. Press the large O-Ring (PN 2210) into the cutout in the bottom of the valve body.
9. Reattach the valve body to the base plate with the two 3/32" hex screws (see Figure 3).
10. Apply a small amount of silicone lubricant to the valve stem and slide it through the ring return and down into the large compression spring. The E-Clip on the stem should rest on top of the ring return. Slide assembly into hole on block.
11. Position the large compression spring (PN 6042) over the stem and ring return. Position the foot control disc over the base plate; make sure the large compression spring is located in the center of the foot control disc.
12. Turn the foot control over while holding the disc and the large compression spring in place. Reattach the disc using the four Phillips head screws. It may be necessary to move the plastic retaining ring around in order to find the holes.
13. Your FC is now ready for use.

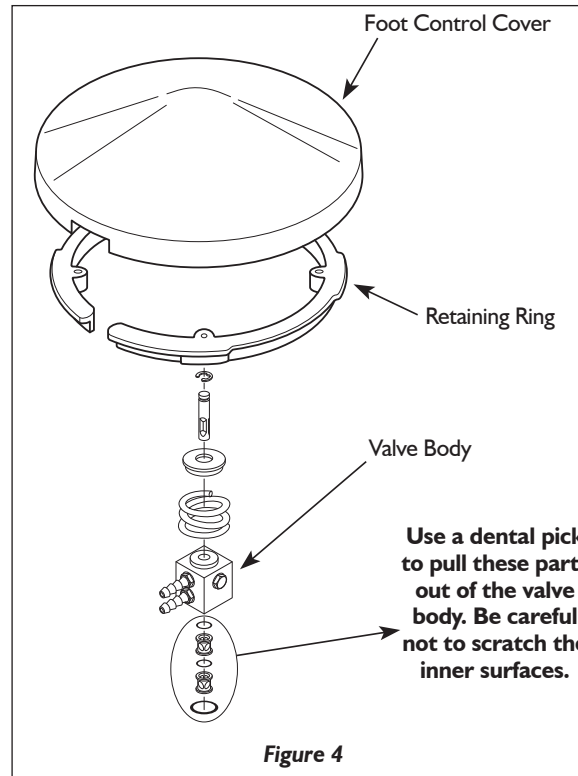

FOOT CONTROL REPAIR KIT, PN 6162

Installation Instructions

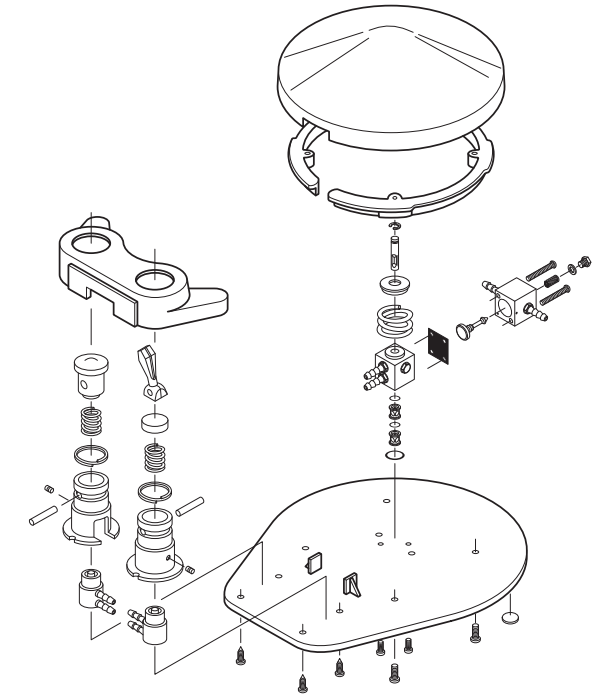

FOOT CONTROL REPAIR KIT, PN 6162
INSTALLATION INSTRUCTIONS

This foot control repair kit contains all of the parts needed to rebuild the valve body in any one of the following foot controls:

- 6305, 6307, 6314, and 6336 Chip Blower FCs
- 6320, 6321, 6332, and 6337 Scaler FCs

This kit includes:

- One compression spring PN 6042
- One small compression spring PN 6036
- Two small O-Rings PN 2205
- One large O-Ring PN 2210
- One valve stem, with E-Clip PN 6096
- One return ring PN 6033

These parts are identified in Figure 1 below:

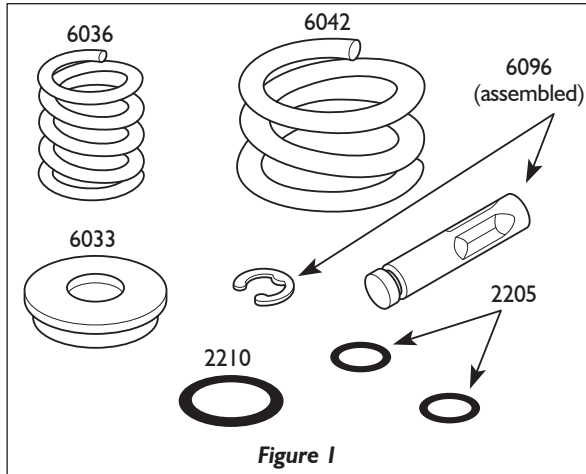

Part number 6036 is a replacement for the spring in a chip blower or scaler button.

Caution: Be sure air supply to FC is off before proceeding.

1. To disassemble the button, remove the O-Ring that encircles the outside of the button housing. Reach under it with a dental pick or other sharp instrument and pull it off. Be careful not to scratch the O-Ring with the dental pick.
2. Locate the retaining pin underneath the O-Ring. Using the dental pick, push the pin out through the button housing (see Figure 2)

FOOT CONTROL REPAIR KIT, PN 6162
INSTALLATION INSTRUCTIONS

3. Lift the button out of the housing. Locate the old spring inside and remove it.
4. Place the new spring (PN 6036) in the button housing. Make sure it is centered over the microvalve in the bottom of the housing.
5. Put the button back in the housing. Position the stud on the end of the button inside the spring.
6. Press down on the button and turn it in the housing until the holes in the button line up with the holes in the housing. Press the retaining pin back into place, making sure it is evenly positioned.
7. Stretch the O-Ring over the button housing and snap it into its original position over the O-Ring.

The remaining parts in the kit are for use in rebuilding the foot control valve, located under the chrome foot control disc.

1. Remove the foot control disc. On the bottom of the foot control, locate and remove the four Phillips head screws shown in Figure 3.
2. Turn the foot control right side up, while holding the disc on. Lift the disc off, exposing the valve body. Leave the plastic retaining ring in the disc.
3. Lift the large compression spring off the top of the valve body. Pull the stem out of the hole in the top of the body. Lift the smaller conical spring off the top of the valve body (see Figure 4).

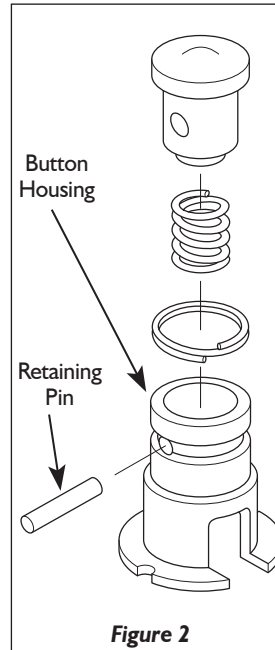

Figure 2

FOOT CONTROL REPAIR KIT, PN 6162
INSTALLATION INSTRUCTIONS

4. Turn the foot control over again and remove the two 3/32" hex screws near the center of the base plate (shown in Figure 3).

CAUTION
When using a sharp instrument in the following steps, use care not to scratch the finished metal surfaces on the valve body. These surfaces must be smooth in order for the O-Rings in the valve body to seal properly.

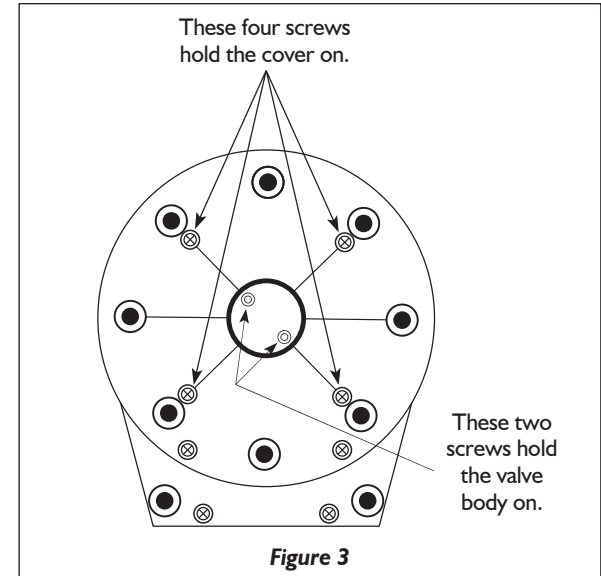

Figure 3

5. Lift the valve body off of the base plate and turn it over. The large O-Ring will be visible in the bottom of the body. Use a dental pick or other sharp instrument to pull the O-Ring out. Using the dental pick, reach into the hole in the bottom of the valve body and pull out the two O-Rings and the two spools shown in Figure 4. **Be careful not to scratch the inner surfaces of the valve body with your dental pick.**
6. Apply a light coating of all purpose silicone lubricant (DCI part number 8032) to all three of the replacement O-Rings.