

# ALTERNATIVE 4128 & 4129 ARM MOUNTED MANUAL CONTROL FOR TWO HANDPIECES

## Installation Instructions

**DCI**



**WARNING:** The arm assembly for this control unit is spring loaded. Do not remove the shipping strap from the arm until the control unit is fully installed. Bodily injury could result from working with the arm assembly unrestrained.

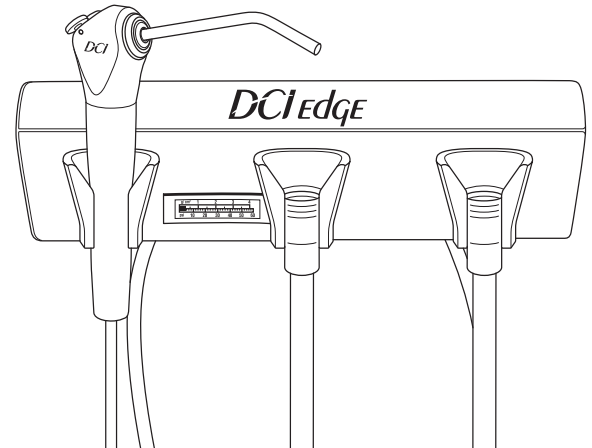

### THE FOLLOWING ITEMS ARE CONTAINED IN THIS PACKAGE:

- One arm assembly and control unit with handpiece tubings and umbilical installed
- One molded plastic tray holder pre-installed on the head
- One standard foot control
- One Precision Comfort syringe
- One syringe repair kit
- One post mounting rotation stop collar with set screws
- One thrust washer
- One 3/32" ball driver
- One 5/64" hex key

### YOU WILL NEED THE FOLLOWING ADDITIONAL TOOLS TO INSTALL THE 4128 & 4129:

- 1/8" and 3/32" hex key
- 1/4" and 1/8" sleeve tool, DCI PN 8060
- Post leveling tool DCI PN 8668

## INSTALLATION INSTRUCTIONS

1. Install the unit post on the chair mount bracket (see Figure 1). Using the post leveling tool DCI PN 8668 and the appropriate hex key, adjust the set screws in the chair mount bracket to set the post in a perfectly vertical position. A slight deviation will cause the control unit and tray to not be level, allowing instruments to roll on the tray.
2. Install the arm assembly with control unit on the unit post as follows: (Figure 1 covers the next four steps).

- Leave the shipping strap on the arm assembly during installation.
- Slide the post mounting rotation stop collar over the unit post. Using a 3/32" hex key, tighten the set screws in the top of the collar after locating it at the desired height.
- Install the thrust washer on top of the collar.
- Install the arm assembly with control unit by sliding it over the post and on top of the thrust washer.
- You may now remove the shipping strap from the arm assembly; the flex arm and control unit will go to its upper limit until you have made all of your tubing connections and the air brake is activated.

3. Route the 5/8" umbilical into the utility center. Make the tubing connections as follows:

- 1/8" red to regulated water (40 psi)
- 1/4" gray to regulated air (80 psi)

The following connections are made at the factory so the unit can be operationally tested. It may be necessary to disconnect them in order to route the umbilical into the utility center. The connections are provided here for reference when reconnecting:

- 1/4" gray (unribbed) line from foot control to the 1/4" gray tubing from the control unit (drive air)
- 1/8" gray to regulated air supply

4. Open the manual shut-off valves in the utility center. Adjust regulated air to 80 psi and regulated water to 40 psi. When adjusting for a lower pressure, make the adjustment, and then press the syringe button to relieve the pressure to get an accurate pressure reading.

5. All of the controls are located on the underside of the control unit.

- The handpiece selector toggle is located in the right front center.
- The handpiece water coolant valve is located in the left front.
- Handpiece pressure adjustment screws are located in the right rear behind the handpiece selector. They require a 3/32" ball driver, DCI PN 9700. Handpiece pressures should be adjusted in accordance with the manufacturer's recommendation.
- The pneumatic arm brake toggle is located in the front right corner. The toggle valve is a three-way normally open valve, keeping air pressure supplied to the pneumatic brake. The brake keeps the vertical position of the arm assembly constant until the operator chooses to change it. To change the vertical position of the arm, pull the toggle forward to release the

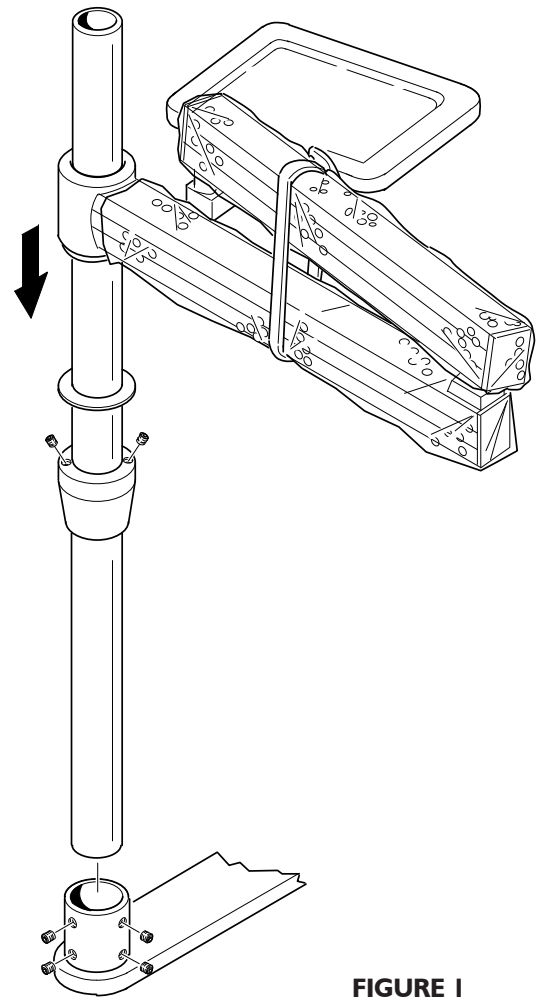

FIGURE 1

