

ASEPSIS SELF-CONTAINED STANDARD DUAL WATER SYSTEMS #8177 & #8179

Installation Instructions



INSTALLATION

- Remove the water system from packaging and inspect.
- For Wall Mounting, select a location, keeping in mind that the system must be accessible for easy bottle replacement and servicing.
- For Post Mounting use a 2" post mount DCI #8137 or 8162.
- Connect the Gray 1/4" line to an air source. Pressure should be between 40 PSI and 120 PSI.
- Connect the Red 1/4" line to the Dental Unit water supply line.

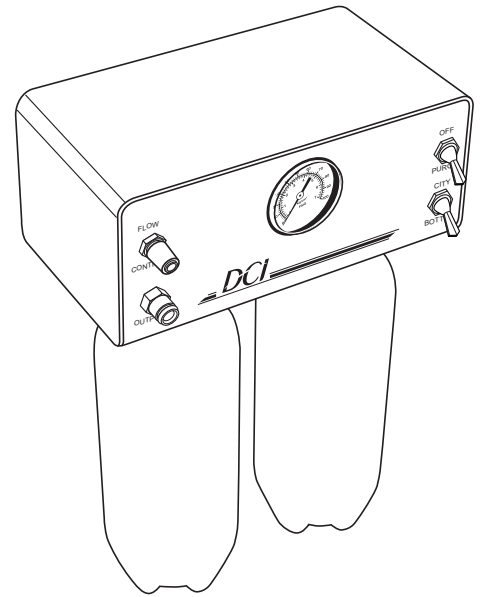

NORMAL OPERATION

- Install the bottle with water or solution you choose, in the selected bottle position.
- Place Master Toggle located on the bottom right rear of chassis in "on" position (to front).
- Check pressure gauge on front panel to assure that pressure reads 40 PSI, (Factory set at 40 PSI). If pressure needs to be adjusted, use regulator located on the bottom left rear of the chassis. Turn clockwise to increase pressure and counterclockwise to decrease pressure.

*** **CAUTION:** Pressure should not exceed 60 PSI ***

- Systems that have two bottles include a bottle selector toggle, located on the bottom of the chassis between the bottles. The toggle will activate one bottle at a time by moving toggle toward bottle you want to use. (Both bottles can not be activated at the same time.)
- The Quick Disconnect located on the lower left corner of the front panel will provide water or solution to auxiliary equipment. The Quick Disconnect source is from the bottle only. The flow control valve above it controls the flow through the quick disconnect. Clockwise reduces flow and counter clockwise increases flow.

AIR PURGING OPERATION

To air purge water lines in the dental unit use the procedure below.

- Place Master Toggle located on the bottom right rear of chassis in "off" position (to rear).
- Activate all Dental Unit instruments that use self-contained water, i.e. air water syringe, handpieces, cup filler, and any other water using attachments. To flush the QD connection, you must insert a #0014 male QD. Attach open-ended poly-flow tubing and drain into proper receptacle.
- Activate Purge Toggle located on upper right corner of front panel. To air purge, place toggle in Purge position (down).
- Flush water lines until all liquid is gone.
- Return Purge Toggle to "off" position (up).
- Follow Normal Operation instructions to continue use.

CHANGING BOTTLE

- Place Master Toggle located on the bottom right rear of chassis in “off” position (to rear).
- Remove empty bottle.
- Replace with a filled bottle.
- Place Master Toggle located on the bottom right rear of chassis in “on” position (to front).

SURFACE CLEANING

- The water system should be wiped down with a mild detergent solution.
- Harsh detergents or chemicals should not be used.

STANDARD DUAL WATER SYSTEMS SCHEMATIC 91607 FOR #8177 & #8179

