

ALTERNATIVE #4376 ARM MOUNTED AUTOMATIC CONTROL FOR THREE HANDPIECES



Operating Instructions

OPERATION AND FEATURES

HANDPIECE HOLDERS

The asepsis handpiece holders are designed to resist chemical discoloration and be easy to clean. The handpiece is activated when removed from the holder and stepping on the foot control disc. Varying pressure on the foot control disc controls speed. The positions of the individual handpiece holders are adjustable. See the section on *adjustments*.

ARM

The *pneumatic arm brake toggle* is located on the underside of the control unit, in the front right corner. The brake keeps the vertical position of the arm assembly constant until the operator chooses to change it. To change the vertical position of the arm, pull the toggle forward to release the brake, reposition the arm to the desired position and release the toggle. It may be necessary to adjust the spring tension on the flex arm section of the pneumatic arm, depending on the extra weight added to the instrument tray. If the control unit drifts out of the vertical position when the brake is released, see the section on *adjustments*.

CONTROL

The *master on-off toggle* controls air and water to the entire system. It is located on the underside of the control unit, in the left front corner.

The *water coolant flow control knobs* control water to a specific handpiece. They are located on the underside of the control unit, in the rear center.

The *drive air pressure gauge* indicates the operating pressure of the selected handpiece. It is located on the front left corner of the control unit cover.

The *drive air adjustment screws* are located on the underside of the control unit, in the right center front. Handpiece drive air pressure should be adjusted to the handpiece manufacturer's recommendation. See the section on *adjustments*.

SYRINGE

The #4376 comes with a standard syringe. The syringe is packaged in a shipping envelope, with operating instructions and a repair kit attached. The syringe goes in the holder on the far-left side of the instrument holder bar.

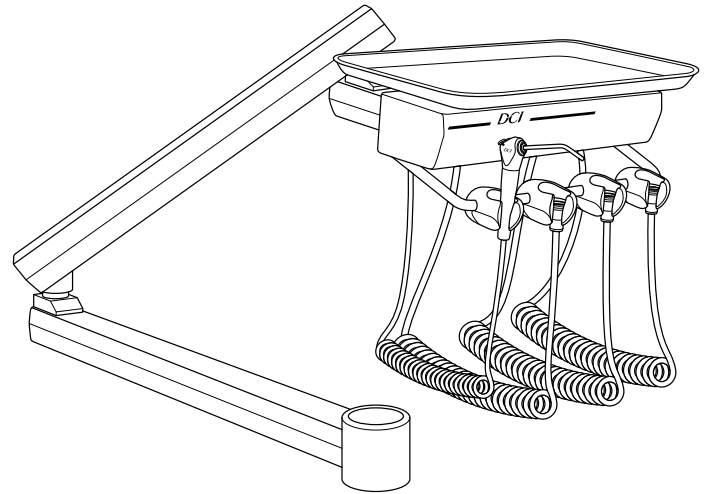

FOOT CONTROL

The foot control is equipped with a wet/dry toggle. When the toggle is positioned toward the blue dot, water will be provided to the active handpiece. With the toggle positioned away from the blue dot, water is turned off. Handpiece speed is controlled with the foot control disc. Varying pressure on the foot control disc controls speed. Air coolant is also provided when you step on the foot control disc.

CLEANING AND MAINTENANCE

Do not use powdered cleansers, scouring pads, or abrasive scrubbers on any of the finished metal surfaces in this unit, i.e., the syringe or the foot control disc. Sodium Hypochloride will also damage these surfaces.

CONTROL HEAD

The control head can be cleaned with most commonly available surface disinfectants. Do not use any Sodium Hypochloride solutions, or any cleansers containing alcohol. These may cause paint and finish discoloration.

DENTAL UNIT WATER LINE MAINTENANCE

The Centers for Disease Control and the American Dental Association can provide recommendations on when to flush your system, for how long, and what to use.

ADJUSTMENTS

SYRINGE BLOCK

Adjustment screws for the air and water flow to the syringe are located on the underside of the control unit, in the front left area. Use the 3/32" ball driver provided with the unit to turn the hex screws counterclockwise to increase the flow of air or water, clockwise to decrease the flow. As you face the control unit the adjusting screw for air is on the right, and the adjusting screw for water is on the left.

HANDPIECE HOLDERS

Each handpiece holder is attached to the instrument holder bar with two screws, located on the underside of the instrument holder. To reposition a instrument holder, loosen the set screws (see Figure 1), move the instrument holder to the desired location, and retighten the screws. You will need a 1/8" hex key.

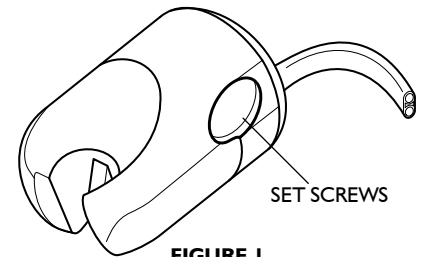

FIGURE 1

FLEX ARM SPRING TENSION

The pneumatic arm brake toggle is located on the underside of the control unit, in the front right corner or front left corner - if unit is left handed. The brake keeps the vertical position of the arm assembly constant until the operator chooses to change it. To change the vertical position of the arm, pull the toggle forward to release the brake, reposition the arm to the desired position and release the toggle. It may be necessary to adjust the spring tension on the flex arm section of the pneumatic arm, depending on the extra weight added to the instrument tray. If the control unit drifts out of the vertical position when the brake is released extend the arm assembly fully and position it at its highest vertical height. Slide the long plastic strip out to expose the supply tubing running inside the arm.

See Figure 2. The opening under the tubing provides access to the handle for the tension adjustment. The handle is located underneath the supply tubing and will present itself if the tubing is moved to one side. Spring tension is adjusted by moving the handle either to the left or the right. If the control unit drifts up, move the handle counterclockwise (as viewed from front of control unit) to reduce tension - disengage collar by moving handle toward the unit head - advance the handle and reengage - repeat until desired tension is achieved. If the control unit drifts down, move the handle clockwise (as viewed from front of control unit) to increase tension - disengage collar by moving handle toward the unit head - advance the handle and reengage - repeat until desired tension is achieved. Replace tubing back to original position and slide the long plastic strip back into place - the tension adjustment handle will fold out of the way automatically.

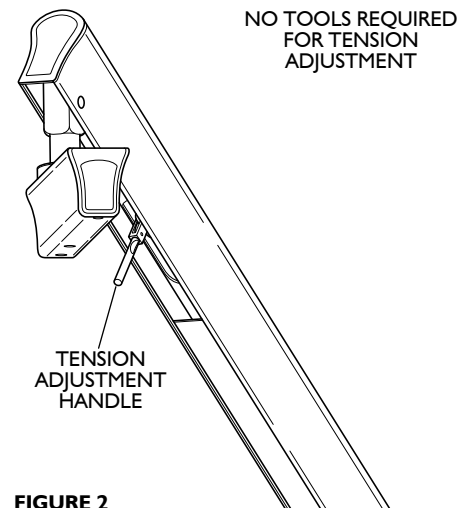

FIGURE 2

NOTE: All of the following adjustments should be made with a bur in the handpiece. Running a handpiece without a bur can damage the handpiece.

HANDPIECE DRIVE AIR PRESSURE

Refer to the manufacturer's literature to determine the recommended drive air operating pressure for your handpieces. You will need a small flat-blade screwdriver to make these adjustments. The master on-off toggle must be in the on position. Install a bur in the handpiece to be tested. Position the wet/dry toggle on the foot control in the dry position. The three handpiece drive air adjustment screws on the underside of the control unit are positioned in the same order, left to right, as the three automatic asepsis handpiece holders are positioned on the instrument holder bar. Place the small flat-blade screwdriver in the adjustment screw that corresponds to the handpiece you are testing. Step on the foot control disc until the handpiece is running at maximum speed. Turn the adjustment screw until the pressure gauge reads a little more than the recommended operating pressure. Then turn the screw until the pressure gauge indicates the recommended operating pressure. Repeat this step for the remaining two handpieces.

WATER COOLANT FLOW CONTROL

Place the master on/off toggle in the on position. Install a bur in the handpiece to be tested. Position the wet/dry toggle on the foot control to the wet position (toward the blue dot). Press on the foot control disc until the handpiece is running at half operating speed. Adjust the water coolant flow control knob for the selected handpiece until a fine spray is present around the bur. Very little water coolant is required to attain the appropriate spray pattern.

