

PELTON & CRANE LF+ REFLECTOR

Replacement Instructions



INSTALLATION

1. Remove Flexible plastic shield by squeezing firmly at the side and pulling one end out from retaining flange.
2. Remove two #6 x 3/4" Phillips flat head screws securing handle assembly to frame. Remove handle and emblem assembly.
3. Pull focus bracket firmly straight out to loosen so there is no contact with reflector. DO NOT REMOVE.
4. Tilt light reflector face down. Remove from one end only, two #6 x 1/4 Phillips truss head screws securing the reflector retaining clamp. Remove clamp and pad assembly (Figure 1 or Figure 2).
5. Reflector will slip out once retaining clamp has been removed. Care should be used in handling the reflector to prevent breakage during removal.
6. Install new replacement reflector. Secure reflector into position by replacing retaining clamp. Use felt strip to provide additional padding on retaining clamp, as needed, for a snug fit.
7. Reposition light head with reflector facing installer.
8. Push focus bracket assembly back into position against reflector frame.
9. Replace handle assembly.

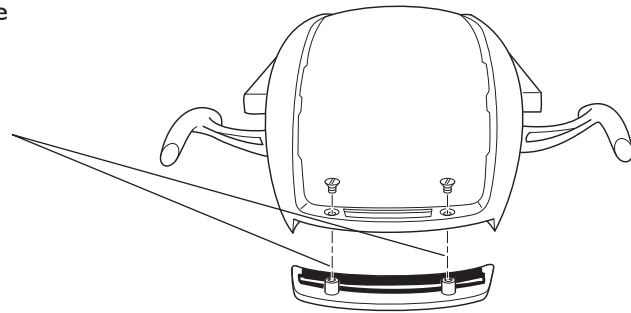

Figure 1
LF + Reflector Retaining Clamp

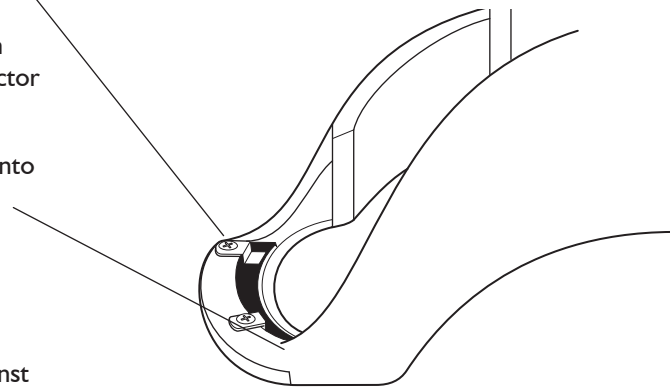

Figure 2
LF + Reflector Retaining Clamp with Support Clip

ADJUSTMENTS

1. Adjustments of the main balance spring will be necessary due to the lighter weight of replacement reflector.
2. Remove screw at point 'A' on both sides of arm.
3. Remove rubber inserts from counterbalance spring covers, bottom end only.
4. Remove counterbalance spring cover on each side by sliding up.
5. Disconnect small counterbalance spring on both sides at point 'B'.
6. Remove retaining stud on both sides at point 'B'.
7. Lift off top arm cover.
8. With arm in horizontal position, turn the adjusting nut at point 'C' twelve complete turns counterclockwise (direction indicated in Figure 3) to loosen.
9. Replace arm cover, then replace retaining studs and springs at point 'B' both sides.

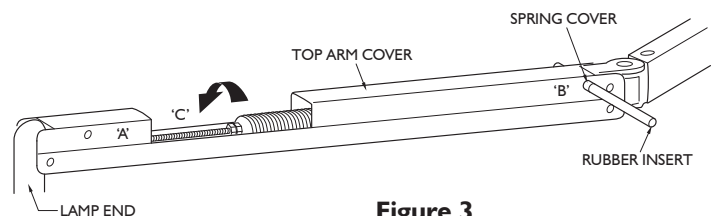

Figure 3
Main Balance Spring Adjustment

NOTE: Check balance of arm to see that same force is required to push arm up and down, thus eliminating drift. If arm is not balanced, repeat operations in steps 5, 6, 7 and then operation 8, turning adjusting nut two complete turns counterclockwise to further loosen, as necessary.

10. Replace spring cover and rubber insert on both sides.
11. Replace screw at point 'A' on both sides.
12. Adjust focus with dimmer control switch on high intensity. Set the lamp focus at 27" (68.6cm) from the oral cavity for an optimum pattern. This will produce an excellent pattern in an 18" (45.7cm) to 36" (91.4cm) range from oral cavity. The lamp may be refocused for an optimum pattern at other operating distances.
13. With plastic shield removed the holes on either side of Pelton & Crane nameplate allow access to two focusing screws (Figure 4). Using a straight screwdriver turn both screws clockwise equally until there are two separate patterns, as shown in Pattern A (Figure 5).
14. Turn each screw counterclockwise equally, one turn at a time, until the patterns are superimposed, as shown in pattern B (Figure 5).
15. Inspect for optimum pattern by blocking out one half of the light. If the pattern shifts, further adjustment is required. Otherwise, focusing of the lamp is completed.
16. If patterns are irregular, as shown in pattern C (Figure 5), turn only one screw until patterns are superimposed.
17. Replace plastic shield.
18. **Warning:** Do not operate light without plastic shield in place. The shield provides protection in case of lamp explosion. If new shield is needed order part number 8601.

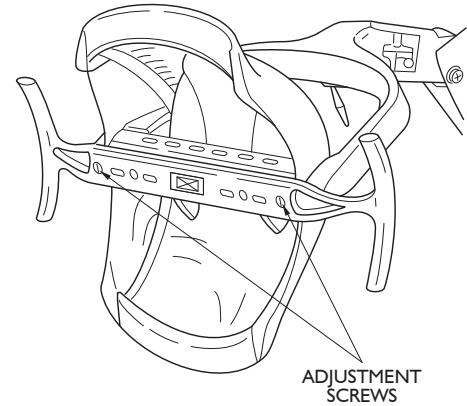

Figure 4
Adjustment Screws for Focus

Warning: Never attempt to remove the main balance spring without securing with the main balance spring safety kit, order P&C part numbers 006742 and 094186.

CLEANING

1. Cleaning the reflector should not be necessary more often than every six months to one year under normal operating conditions. The LF+ is a precise optical instrument that when properly cared for will provide years of trouble-free operation. For normal cleaning of the front surface, the following should be performed:
 - Saturate clean, soft, lint-free cloth with alcohol.
 - Wipe reflector from surface in one direction only.
 - Using clean, dry cloth wipe in the same direction to remove all alcohol.
2. The rear surface of the reflector may be cleaned, as necessary, with a soft cloth dampened with a mild detergent. Take care not to permit cleaning solution to contact front surface.

Caution: Do not use abrasives, chlorine or ammonia when cleaning reflector. Do not rub heavily. Do not clean when reflector is hot. Do not soak in cleaning solution. Do not routinely clean front of reflector at more frequent intervals than specified. Failure to comply with any of the above cautions can result in degradation of the optical coating.

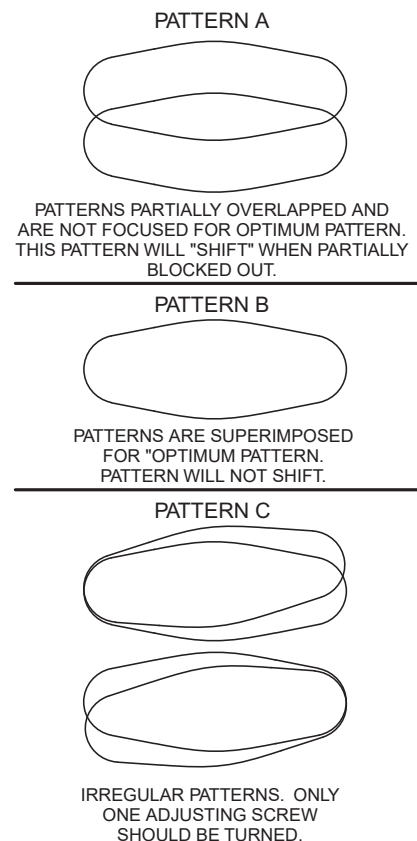

Figure 5
Focusing Lamp Patterns