

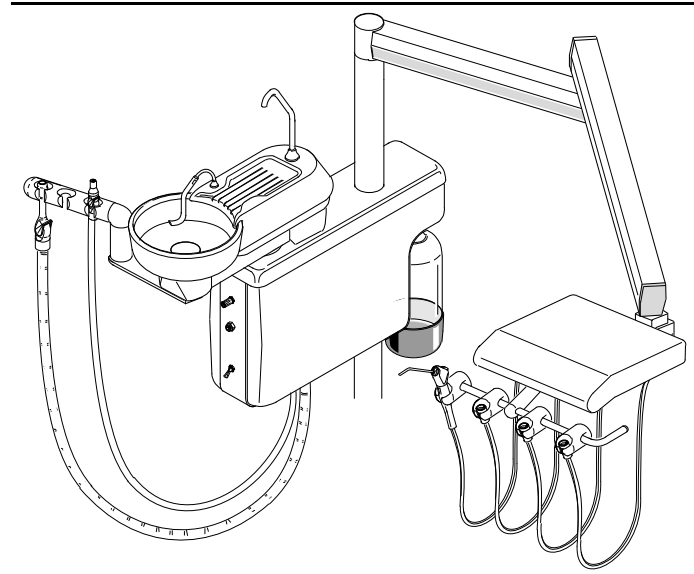

Committed To Innovation

**Owner's Manual for the
System 6000, Model #6505**



Contents

Section One: Asepsis Automatic Control	Page 1
Operation and Features	Page 1
Adjustments	Page 3
Section Two: Foot Control	Page 6
Section Three: Gravity Drain Cuspidor	Page 6
Section Four: Assistant's Instruments	Page 8
Section Five: Post Mount Utility Center	Page 8
Section Six: Cleaning and Maintenance of the 6505	Page 10
Asepsis Automatic Control	Page 11
Gravity Drain Cuspidor	Page 11

Section One: Asepsis Automatic Control

Operation and Features

Arm

The arm is equipped with a pneumatic brake that holds the control head in place. The brake toggle is located on the right underside of the control head, behind the water coolant flow control knobs (see *Figure 1* for location of all controls). To position the arm, pull and hold the toggle forward, move the arm to position the head, then release the toggle.

It may be necessary to adjust the spring tension on the arm, depending on how much weight is on the instrument tray. If the control head drifts out of position when the brake is released, see the section below on adjustments.

Handpiece Holders

The handpiece holders on the control head are automatic. With the master air toggle in the on position, the handpiece may be activated by depressing the foot control. Speed of the handpiece is also regulated with the foot control.

The position of the handpiece holders is adjustable. See the section below on adjustments.

Autoclavable Syringe

The 6505 control head comes with a deluxe autoclavable syringe. The holder for the syringe is on the far left side of the tool bar. An instruction booklet is provided.

Controls (*Figure 1*)

The **master on-off toggle** activates the air and water automatic

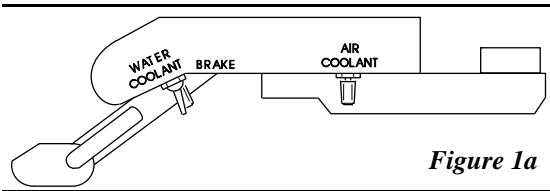

Figure 1a

shut-off valves that supply air and water to the entire system. On the underside of the control head, it is located on the left side toward the front.

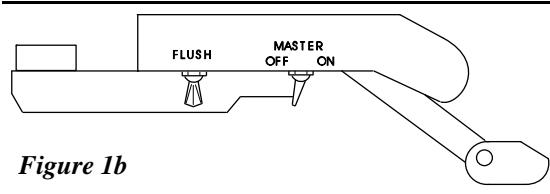

Figure 1b

There is a **water coolant flow control knob** for each of the three handpieces, also located on the underside of the control head,

along the right front side. They are arranged in the same order as the handpiece holders\tubings.

The **toggle for the pneumatic arm brake** is on the right underside of the unit, next to the water coolant flow control knobs.

The **air coolant flow control knob** is on the right side of the control head, toward the back.

The **drive air pressure controls** are located inside the control head, on the control block. Drive air pressure and coolant flow should be adjusted according to the handpiece manufacturer's specifications.

The **handpiece flush toggle** is located behind the master on-off. Handpiece tubings can be purged of contaminants and debris by activating this toggle. See the section on cleaning and Maintenance for instructions.

For **access to the inside of the control unit**, locate two screws on the underside of the unit, toward the front. Use a 1/8" hex key to remove the screws. The cover of the unit can now be raised to expose the control block, pressure gauge and plumbing.

Adjustments

Syringe Block

cleaner which biologically degrades wastes into natural elements.

Post Mount Utility

The solids collector contains a removable screen, which should be emptied, cleaned and disinfected at least once a week. To remove the lid from the solids collector, shut off the central vacuum, or open one of the universal valves if you leave the central vacuum on. The screen can be cleaned and reused or replaced with a new one.

External surfaces of the solids collector can be cleaned with a solution of warm water and a mild detergent.

To replace the covers, fit them back on to the chassis. Push up on the black knobs and turn gently until the threads engage. Tighten the knobs.

Section Six: Cleaning and Maintenance of the 6505

Asepsis Automatic Control

Note

Do not use powdered cleansers, scouring pads, or abrasive scrubbers on any of the finished metal surfaces in this system (for example, the autoclavable syringe or the foot control disc). Sodium Hypochlorite will also damage these surfaces.

Control Head

The control head and other components of the system can be cleaned with any commonly available surface disinfectant. Some disinfectants can cause discoloration with repeated use. This can be minimized by frequent cleaning with soap and water. If you use an iodophor, follow up with an Iodophor Neutralizer.

Handpiece Flush

The handpiece flush toggle runs a larger than normal amount of system water through the handpiece tubings, and through the handpieces if they are attached.

To flush the system, hold all of the water-cooled handpieces (or the tubings if the handpieces are not attached) over a basin or sink. Make sure the water will be directed into the receptacle. Pull and hold the flush toggle to the on position. The toggle snaps back to the off position when released. The Center for Disease Control and the American Dental Association can provide recommendations on when to flush your system, and for how long.

Gravity Drain Cuspidor

To prevent buildup of any debris, daily flushing of the cuspidor is recommended. Eco Vac Vacuum System Cleaner (*DCI part numbers 5835 and 5837*) is a non-toxic, environmentally safe

Adjustments to the syringe air and water flow are made on the syringe block. The block is located inside the control head, in front of the drive air pressure gauge (See *Figure 3*).

Turn the hex nuts clockwise for less air or water flow, counter-clockwise for more air or water flow. Use the 3/32" ball driver provided with the unit.

Handpiece Holders

The handpiece holders are attached to the tool bar with two set screws. To reposition a holder, loosen the screws in the bottom of the holder, position as desired, and retighten the screws. You will need a 3/16" hex key.

Arm Spring Tension

To adjust the tension in the arm spring, extend the arm fully and position it as far above the floor as possible. Using a 5/64" hex key, remove the

access plate from the underside of the top section of the arm (see *Figure 2*). Slide the long plastic strip out to expose the tubing running inside the arm. An opening under the tubing provides access to the spring and to the brass tension adjustment collar. Spring tension is adjusted by turning the collar. To turn the collar, insert a flat bladed screwdriver

into one of the vertical slots. Gently pry against the edge of the opening in the arm until the collar turns.

If the control head drifts up, tension is too high. Turn the collar counter-clockwise. If the control head drifts down, turn the collar clockwise to increase tension.

Turn the collar two or three complete turns. Then, release the

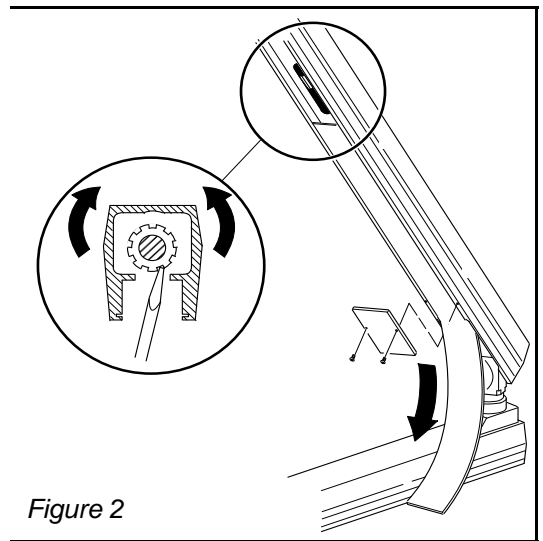

Figure 2

brake and see if the control head moves. Continue adjusting in increments of two or three turns as needed.

Handpiece Coolant Flow Control

Note

All of the following adjustments should be made with a bur in the handpiece. Running a handpiece without a bur installed can damage the handpiece.

Air and water coolant adjustments are made with the air and water coolant flow control knobs. Your handpieces must be in place in order to make these adjustments.

Install a bur in one of the handpieces.

Air Coolant

Place the wet/dry foot control toggle in the dry position (away from the blue dot).

Press on the foot control disc until the handpiece is running at half speed. While the handpiece is running, turn the air coolant flow control knob to provide a strong flow of air. Turn the knob counterclockwise to increase the flow; turn it clockwise to decrease the flow. This adjustment affects all three handpieces.

Water Coolant

Water coolant flow adjustments are made independently for each handpiece.

To adjust water coolant flow, move the wet/dry toggle on the foot control to the wet position (toward the blue dot).

Press on the foot control disc until the handpiece is running at half speed.

While the handpiece is running, turn the corresponding water coolant flow control knob to provide a fine mist of water around the bur (the knobs are arranged across the bottom of the control head in the same order as the handpiece holders/tubings). Very little water coolant is required. Turn the knob counterclockwise to increase the flow, clockwise to decrease the flow.

Self Contained Water Supply (Figure 8)

The reservoir for the self contained water supply is a 2-liter bottle, mounted on the Post Mounted Utility Center. Pressure in the bottle is controlled with a mini-regulator, which is pre-set to 40 psi, the maximum allowable. Pressure can be decreased by turning the knurled knob on the regulator counter-clockwise (the regulator is inside the PMU). Do not increase the pressure.

The top of the bottle is threaded into a fitting inside the PMU. To remove the bottle for filling, turn it counter-clockwise to unscrew it from the fitting. Unscrew the bottle slowly to avoid a sudden release of air pressure.

With the bottle removed, you may hear a faint hissing sound as pressurized air bleeds through the clear tubing in the bottle fitting. This is normal.

After filling, thread the short length of clear tubing into the mouth of the bottle. Then, screw the bottle back into the threaded fitting. Snug the bottle down into the threads to provide a seal. The bottle will pressurize automatically.

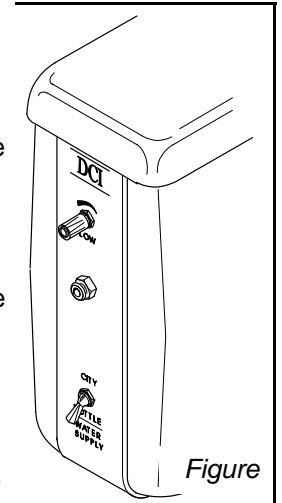

Figure

Access (Figure 8)

Both of the side covers on the PMU are Removable for access to the syringe block and the utility connections; Locate the black knobs on the underside of the PMU. Turn them counterclockwise until you feel the threads disengage. Do not attempt to remove the knobs; they are designed to stay in place when the covers are removed.

Pull the side covers off. The syringe flow adjustment screws are on the syringe block. To make adjustments, use the 3/32" ball driver provided with the system.

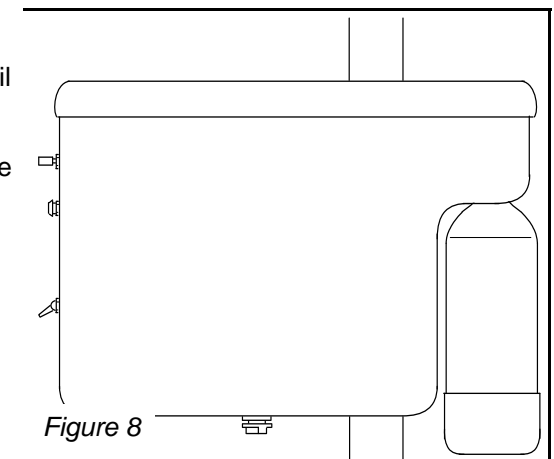

Figure 8

housing.

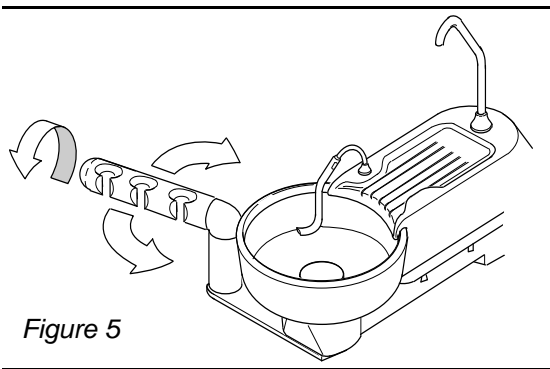
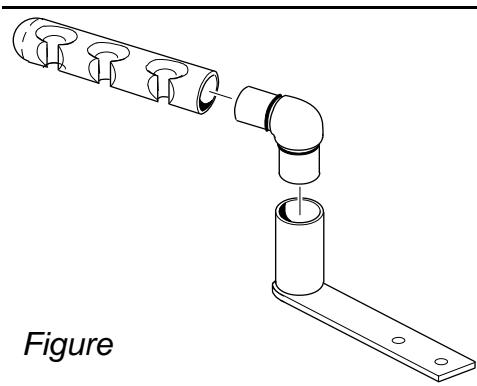

Figure 5

For easy cleaning and maintenance, the holder bar can be disassembled. Pull the bar toward you while twisting slightly. The right angle fitting that the bar snaps into can be removed in the same way. To replace either part, align with the mating part and press together until the o-ring seats. There will be no

gap between the two parts when they are properly seated (see Figure 6)

Section Five: Post Mount Utility Center



Figure

Solids Collector

The solids collector is located in the top of the post mounted utility center, under the cuspidor housing. Push the cuspidor aside for access.

Water Outlet with Flow Control (Figure 7)

The water outlet is on the front panel of the post mounted utility center; the flow control

knob is just above it. The outlet accepts a 1/4" quick disconnect fitting (DCI Part Number 0014).

Water Supply Selector

The post mounted utility is equipped with a self-contained water supply. The system can also run on city water. Desired supply is selected with a toggle, labeled "water supply", located on the front panel of the post mounted utility, below the quick-disconnect water outlet.

Repeat this procedure for the other two handpieces.

Drive Air Pressure

You will need a small, flat bladed screwdriver to make this adjustment.

To determine the recommended drive air pressure for your handpieces, refer to the handpiece manufacturer's literature.

Drive air adjustment screws are located on the control block, inside the control head.

Remove the screws and lift the cover of the control head to expose the control block. The drive air pressure gauge is next to it (Figure 3).

Install a bur in the handpiece you are going to adjust. Install a DCI handpiece pressure gauge (DCI catalog number 7263) below the handpiece. Trace the tubing from the handpiece to the control block to determine which adjustment screw will affect the handpiece you have selected. Position the screwdriver in the adjustment screw. Press on the foot control disc until the handpiece is running at maximum speed.

Turn the adjustment screw counter clockwise for less pressure, clockwise for more. Adjust to the manufacturer's recommendation.

Due to pressure loss along the tubing, the handpiece pressure gauge in the control head will read slightly higher (14 to 16 psi) than what is actually available at the handpiece. The in-line gauge gives an accurate indication of pressure at the handpiece.

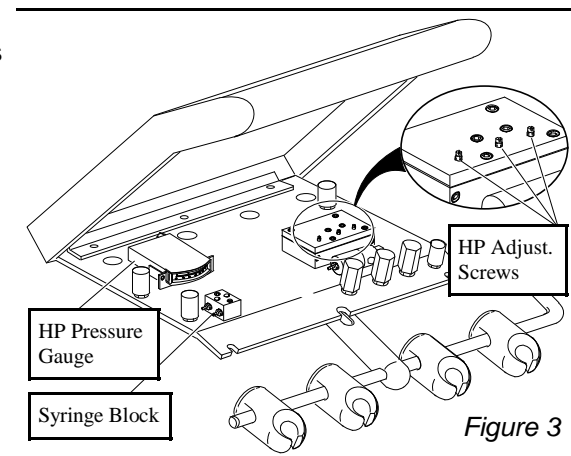

Figure 3

If you do not have an in-line gauge, adjust handpiece pressure

until the gauge in the control head reads slightly higher (10psi) than the handpiece manufacturer's recommendation.

Repeat this procedure for each handpiece.

Section Two: Foot Control

Pressure to any part of the foot control disc provides drive air to the active handpiece. Increased pressure provides increased drive air. Stepping on the foot control also turns on air and water coolant.

Water coolant can be shut off by flipping the wet/dry toggle on the foot control to the off position (away from the blue dot).

Section Three: Gravity Drain Cuspidor (Figure 4)

Cup Filler

The cup filler on the cuspidor is operated by a momentary toggle. As you face the cuspidor bowl, there are two momentary toggles on the lower right side of the cuspidor housing. The toggle for the cup filler is toward the rear. Pull and hold the toggle toward you to turn the water on. Release the toggle to turn the water off.

Timed Bowl Rinse

The toggle for the timed bowl rinse is just in front of the water spout toggle. To activate the rinse, pull the toggle forward and release it.

The duration of the rinse can be adjusted. On the lower left side of the cuspidor housing, locate a control knob. Rotate the knob to adjust the duration of the rinse.

The rinse spout is moveable; position as desired.

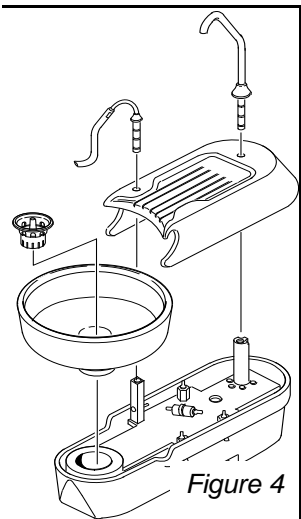

Replaceable Screen

The screen in the bottom of the cuspidor bowl is disposable. Replacements are available in the DCI catalog, part number 5312.

Removeable Spouts

The cup filler and the bowl rinse spouts are removeable for cleaning, disinfecting or autoclaving. Pull firmly on the spouts to remove them. To replace, insert the spout in its receptacle and push until the o-rings seat. The cup filler has a small hole on the underside of the flange above the o-ring fittings. This hole mates with a tab to ensure that the cup filler is properly oriented over the drain area.

The o-rings on the spouts are autoclavable.

Removable Bowl

The cuspidor bowl can be removed without tools. With the spouts removed, lift the cover off of the cuspidor housing (see figure 4). To remove the bowl, pull it straight up to disengage the o-rings from the drain fitting.

To reinstall, push the bowl back into the drain fitting. Position the cover over the holes for the spouts, and press the spouts back into place.

Section Four: Assistant's Instruments

The assistant's instruments are located in a tool bar mounted on the cuspidor housing. They include an HVE and an SE. All come with their own operating and maintenance instructions.

Holder Bar (Figure 5)

The holder bar position is adjustable in two degrees of motion. Twist the bar to rotate it. Pull or push on the bar to pivot. In addition, the entire holder bar assembly can be moved by repositioning the mounting bracket attached to the cuspidor