

AUTOCLAVABLE EURO-STYLE SYRINGES

**3349, 3350, 3355, 3357, 3359,
3361, 3406, 3351**

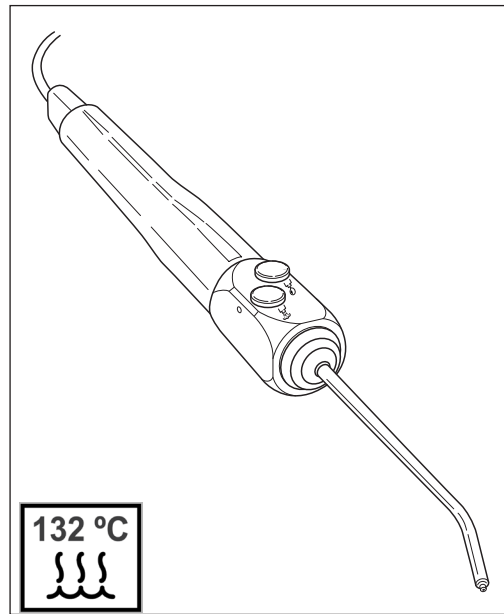

Figure 1: The Autoclavable Euro-Style Syringe

Your new Autoclavable Euro-Style Syringe from DCI represents the highest level of engineering achievement in the dental equipment industry today.

This 3-way syringe gives precise finger-tip control of water, mist or dry air for rinsing, cooling or drying the preparation area.

Your syringe is totally autoclavable and features DCI's patented Quick-Change tip system for maximum patient safety.

By following these use and maintenance instructions, this syringe will provide a lifetime of dependable service.

R_x DCI 3-way syringes are designed for professionals in the dental industry to supply air and water to the oral cavity during dental procedures for rinsing purposes. It is operated by depressing the air, water or both buttons simultaneously to precisely deliver water, mist or dry air for rinsing, cooling or drying the preparation area.

INSTALLATION

Turn off the air and water supplies. Determine which of the syringe tubes leads to the air button and connect that tube to the air outlet on the dental unit or syringe manifold. Connect the other tube to the water outlet. For circulating syringes, the third tube is the return water, and is routed to the drain. Maximum operating pressures: Air 80 psi, Water 40 psi. DCI dental units use a manifold block to which the tubing from the syringe assembly gets attached. Supply lines going into the block are: Red or blue tubing water and clear, gray or yellow tubing for air. See Fig 1 below for output details which is were tubing from syringe get attached.

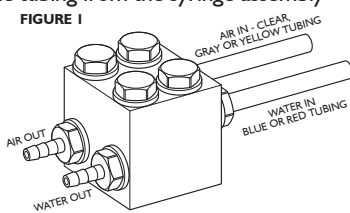

USE AND CARE

OPERATION

The syringe head is imprinted with symbols indicating the button functions. The button on the left is water, and the one on the right is air. Press both buttons simultaneously for steady uniform mist.

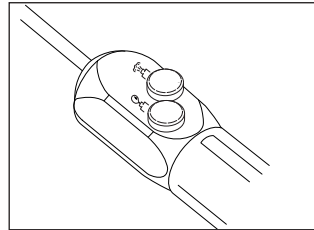

Figure 2: The Water and Air Symbols



CHANGING THE TIP

A sterile syringe tip should be installed for each patient. To prevent contamination, sterile tips should be handled with a sterile gauze pad.

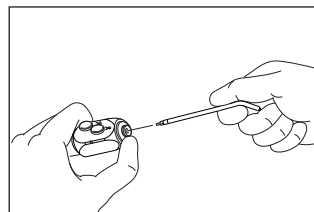

Figure 3: Changing the Tip

To remove the syringe tip, press down on the large collar. When you feel a soft "click", the tip may be pulled straight out. Hold the collar down and insert the new tip. Be sure to press it all the way in, then release the collar.



CAUTION! Syringe tip may eject if it is not properly installed. Test the installation by giving a firm pull on the tip to assure that it is inserted all the way, and that the locking mechanism is fully engaged.

SYRINGE REMOVAL AND REPLACEMENT

The syringe is engineered for quick, easy removal for cleaning and sterilization. The quick disconnect feature incorporates an internal shut-off valve that prevents leakage when the syringe is removed, even if the dental unit remains turned on.

To remove the syringe, grip the gray sleeve at the base of the handle, and turn it counterclockwise a quarter turn until it stops. Pull the syringe away from the Quick-Disconnect (Q.D.) cartridge.

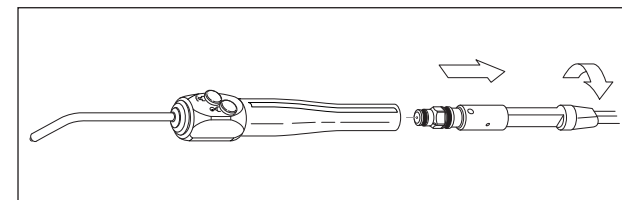

Figure 4: Syringe Removal



NOTE: Syringes and tips are shipped non-sterile.

IMPORTANT

Note the white sleeve around the syringe tubing. This is furnished to protect the Q.D. cartridge while the syringe is away for sterilization. After removing the syringe, slide the sleeve up the tubing until the Q.D. rests in it, and then place it in the syringe holder. This minimizes risk of damage to the Q.D. cartridge or of inadvertently opening the air and water shut-off valve in the Q.D.

To install the syringe, slip the Q.D. cartridge all the way into the syringe handle, and then turn it clockwise a quarter turn until it stops. This will turn the air and water on, making the syringe operational.

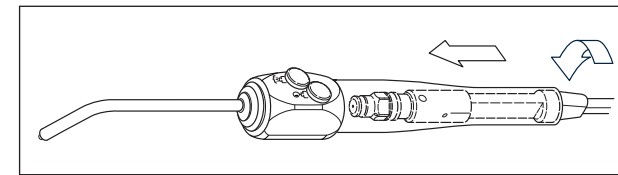

Figure 5: Syringe Insertion

To install the syringe, slip the Q.D. cartridge all the way into the syringe handle, and then turn it clockwise a quarter turn until it stops. This will turn the air and water on, making the syringe operational.

If the Q.D. cartridge does not slip easily into the syringe handle, hanging up on the locking balls, it means that the shut-off valve has been rotated. Do not try to force the cartridge in. Remove the Q.D. cartridge and turn the hex-shaped portion counterclockwise as far as it goes (a quarter turn) to close the valve and allow installation of the syringe.

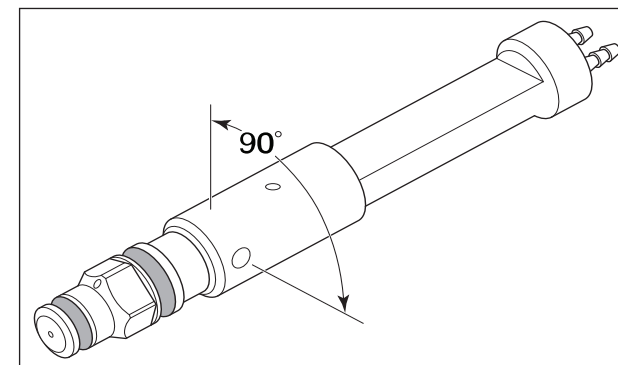

Figure 6: The Q.D. Cartridge (shut-off valve detail)

**CLEANING, DISINFECTING AND
STERILIZATION**

CLEANING

Clean the external surfaces of the syringe using a solution of mild detergent and warm water. A soft-bristled brush may be used to clean around the buttons and tip collar.

Thoroughly rinse the syringe with clear water, then dry with a clean, soft, lint-free cloth.



CAUTION! Never use powdered cleansers, scouring pads or abrasive scrubbers, any of which can damage the surface finishes of the syringe. Stubborn debris can usually be removed easily after soaking in warm water.

DISINFECTING

The use of chemical disinfecting agents is not necessary if the syringe is going to be sterilized. While their use may be easy and quick, it is important to know the effectiveness of any chemical disinfectant against the various agents of infection that may be encountered.

The use of an EPA-registered hospital disinfectant is adequate. Follow disinfectant manufacture's instructions for use when disinfecting syringes.

STERILIZATION

Your Autoclavable syringe is specifically designed to be removed from the QD Cartridge for sterilization. In any situation involving high-risk patients, it is recommended that the syringe be removed for sterilization along with the other instruments used.

The Quick-Change syringe tips should always be replaced with sterile ones before each patient.

Before sterilizing

Clean syringe head and tips under running water for 30 seconds with a soft brush and place in an ultrasonic bath with an enzymatic cleaner to remove superficial debris prior to sterilization; any debris may reduce the effectiveness of the sterilization. Sterilization process is by steam autoclave.



Parameters:
For unwrapped syringe head: 132°C (270°F) for 3 minutes at temperature when using a gravity displacement autoclave. For syringe tips

For unwrapped syringe tips: 132°C (270°F) for 3 minutes at temperature when using a gravity displacement autoclave.

For wrapped syringe tips: 132°C (270°F) for 3 minutes at temperature when using a gravity displacement autoclave.

TABLE 1: TROUBLESHOOTING GUIDE

The DCI Autoclavable Syringe is engineered for dependability. The troubleshooting guide gives the corrective action to be taken for the problems you may encounter.

Problem	Solution
Leakage around button	Replace button assembly or button O-Ring.
Leakage from Syringe tip	Replace valve core.
Momentary spray of water when air button is pressed	(A) Damaged syringe tip end: replace tip. (B) Replace the small O-Ring located behind the Quick-Change adapter.
Leakage from the syringe handle	Replace the O-Rings on the Q.D. cartridge tip.
Constant mist when the water button is pressed	Replace the small O-Ring on the Q.D. cartridge tip.

MAINTENANCE

Most service that will ever be needed can be easily done using the tools and parts in the Autoclavable Syringe Repair Kit (DCI part No. 3072).

LUBRICANT

All of the internal O-Rings and valve seals will perform better if lightly coated with All Purpose Lube (DCI Part No. 8032). Anytime you replace O-Rings, they should be lubricated before installation.



CAUTION! The use of other types of lubricants may cause the O-rings deterioration resulting in syringe malfunction or failure.

BUTTON AND VALVE

Before removing the syringe button, disconnect the syringe from the Q.D. cartridge. Use a non-metallic device such as a DCI button removal tool PN 8059, tongue depressor or Popsicle stick to gently pry the button valve out of the syringe body. Be careful not to lose the small coil spring that is located beneath the button.

Use the valve core tool (Part No. 3096) to unscrew the valve core from the syringe body. When installing the new valve core, do not over-tighten it. Excessive tightening may impair valve operation.



CAUTION! Do not install a used valve core. It may not seal properly and cause syringe to leak.

To replace the O-Ring on the syringe button, remove the old O-Ring carefully, so as to avoid damaging the button itself. Push the replacement O-Ring into its groove on the stem of the button.

Drop the coil spring into syringe body, and then carefully push the button into place. See Figure 7.

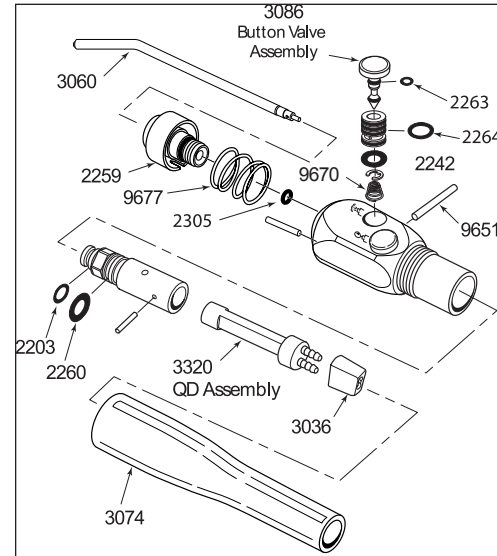

Figure 7: Illustrated Parts Breakdown

TIP ADAPTER & COLLAR

Remove the syringe tip, and then use the hex key furnished with the Autoclavable Syringe Repair Kit to unscrew the tip adapter. Remove the adapter, collar and spring from the syringe body.

Use a dental pick or a bent paper clip to remove the tiny O-Ring from the bottom of the bore in the syringe body. Be especially careful not to nick or scratch the sealing surfaces. The easiest way to install the replacement is to slip it onto the end of a syringe tip, lubricate the O-Ring, and then insert it into the bore. The O-Ring around the outside of the adapter is thin and fragile, so the new one has to be installed with care.

Before reinstalling the adapter and collar assembly, look down into the bore in the syringe body and assure that the alignment pin is in place. With the spring in place in the collar, align the slot in the collar with the pin, and then push the collar into the syringe body.

Use the hex key to carefully screw in the adapter. Tighten the adapter firmly (20-25 in-lbs torque). If you don't have a torque measuring device, hold the hex key by the short end and tighten the adapter as tight as you can. This method installs the adapter to approximately 20-25 in-lbs torque.

Q.D. CARTRIDGE O-RINGS

NOTE

Before performing any service on the Q.D. cartridge, it is necessary to turn off the air and water, and bleed pressure from the system by running a handpiece.

Removing the syringe from the Q.D. cartridge gives you access to the two O-Rings on the end of the adapter. A bent clip or a dental pick can be used to remove the O-Rings.

IDENTIFY THE AIR TUBE

Before undertaking further disassembly of the Q.D. Cartridge, it is necessary to identify and mark the air supply tube going to the syringe. Turn the hex shaped nut at the end of the cartridge clockwise as far as it turns (a quarter turn).

Look for the air outlet just above the hex-shaped part of the tip. The air supply tube is the one aligned directly below the outlet. Use a pen to mark the air tube for reference. See Figure 8.

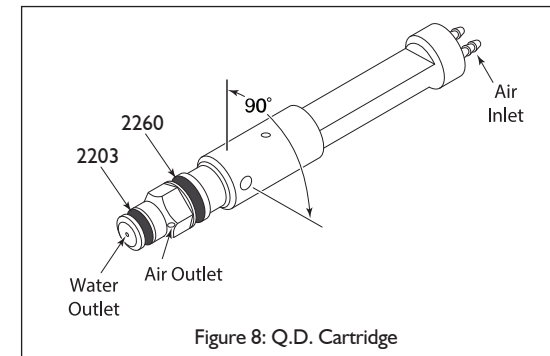

Figure 8: Q.D. Cartridge

SERVICE PARTS & TOOLS

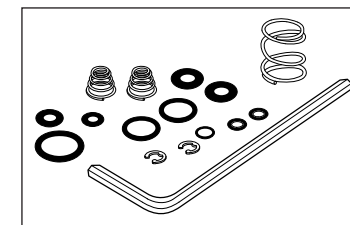

Figure 10: Autoclavable Euro-Style Syringe Repair Kit, Part No. 3045

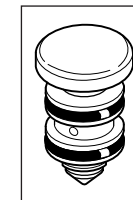

Figure 11: Button Cartridge, Part No. 3086

STORAGE

STORAGE

Store in a dry, dust free location and do not mix with contaminated instruments.

Sterilized syringe tips shall be kept in a sterilization wrap or pouch to maintain sterility. Refer to the instructions for use from the sterilization packaging manufacturer to determine how long sterility can be maintained.

DISPOSAL

Contact your local authorized dealer for disposal of this device to ensure compliance with local environmental regulations.

PRODUCT SUPPORT

For additional product support, contact DCI Customer Service at 1(800)624-2793

ONE YEAR GUARANTEE

DCI has put a lot of time and effort into designing, manufacturing or selecting all the fine products we sell. Therefore we are able to fully guarantee all our products to be free of manufacturing defects for one year from time of purchase. Should product fail for any reason due to manufacturing defect, DCI will repair or replace that product at no charge to the customer. Beyond the one-year period, we still back everything we sell with service at little or no cost to you.

You are responsible for proper care and maintenance of products purchased from DCI, and our guarantee does not cover damage resulting from improper maintenance or installation, accident or misuse. The guarantee does not cover damage resulting from use of surface disinfectants not approved by DCI.

No other warranties as to merchantability or otherwise are made.